

Peerless Home Area Network for Guesstimating in Smart Grid

P.Venkateswari

PG Scholar

Francis Xavier Engineering College
Vannarpettai, Tirunelveli
venkateswari308@gmail.com

Abstract: *The electric power industry is experiencing many challenges in the recent scenario. The significant developments were adapted based on smart grid technology—an automated system with improved communication and Electric Vehicles (EVs). It entirely changes the way of energy consumed by residential customers. Advanced Metering Infrastructure (AMI) is implemented at residential levels to incorporate the changes. With the introduction of AMI technology, a two way communication became possible between a “smart” meter and the control center as well as the meter and residential power equipment. It is concentrated on different aspects of communication between the AMI and terminal residential equipment. The Home Area Network (HAN) used for a smart-meter application should have enhanced security features to assure that the necessary and accurate information is communicated to the smart meter by every corresponding equipment. The purpose here is to enhance the security features and for balancing load condition and to overcome certain constraints associated with electric meter.*

Keywords: Home Area Network (HAN), Advanced Metering Infrastructure (AMI), Electric Vehicles (EVs).

1. INTRODUCTION

This concept made possible installation of a smart meter in every customer premises so it can communicate with appliances and devices and control their operation. The smart meter has the capability to control how many devices can currently operate thus it is a great tool in case of achieving load balance. It will monitor and transfer the amount of energy usage status to electricity board using smart and RF transceiver. The relay is used to take necessary measures to prevent overloading/short circuiting. It saves money by which AMI enables the appliances to operate at lower demand, which eventually have lower electricity rate.

An electricity meter or energy meter is a device that measures the amount of electric energy that has been consumed by a residence, a business, or an electrically powered device. Electric utilities make use of electric meters installed at customer premises to measure the amount of electric energy delivered to their customers which will be used for billing purposes. They are calibrated in billing units, the most common unit will be kilowatt hour [kWh]. These readings are periodically read once each billing period.

The rest of this paper is organized as follows. In Section 2, the Identification of problems formulation related to the existing methods. Section 3 presents detailed description of proposed techniques for solving plant related issue. Experiment results and discussions are described in Section 4. Finally, the conclusion and further enhanced are given in Section 5.

2. PROBLEM DESCRIPTION AND PREVIOUS WORK:

Conventional reading is suitable for a yearly reporting and billing. Service technicians can arrange target dates with the inhabitants in the flats by reading out the displayed values on the different meters water meters, gas and electricity meters

These values will be then sent to the billing center after a time period in order to generate the bills. The manual meter reading will generally have some drawbacks, it has high operational costs even a service technician has to go to each premises and read out all the values of the meters. The further drawback is consumer should be also to allow the service technician for taking the meter values, which is an inconvenient one. The manual reading might leads to errors, because of the service technician he might mistake sometime

The current scenario electric meters are typically calibrated in billing units, the most common one being the kilowatt hour. Periodic readings of electric meters establishes billing cycles and energy consumed during a cycle. The present system faces the following challenges:

- Technician has to visit the place every month.
- The reading is to be fed into the computer.
- The bill generated is to be sent.
- The consumer pays the amount at the electricity board office.
- The consumer will have to stand in long queue for making the payment.
- Delay in initiating action for non-payment.

3. PROBLEM SOLUTION:

The system is used to monitor and transfer the energy usage status of the consumer to Electricity board using smart meter and ZigBee transceiver. Energy usage status includes voltage, current, power which can be viewed through the LCD display. ZigBee technology is a new standard in wireless personal area. A new wireless meter-reading system based on ZigBee protocol presented comprises both ZigBee network and database management system and it find many advantages such as low cost, low power consumption, and low data rate.

3.1 Transmitter side and Receiver side:

A power supply is an device that supplies electrical energy to one or more electric loads. A regulated power supply is one that controls the output voltage or current to a specific value; the controlled value is nearly constant despite

of variations due to load current or the voltage supplied by the power supply's energy source. Nowadays DC voltage sources or power supplies are mostly

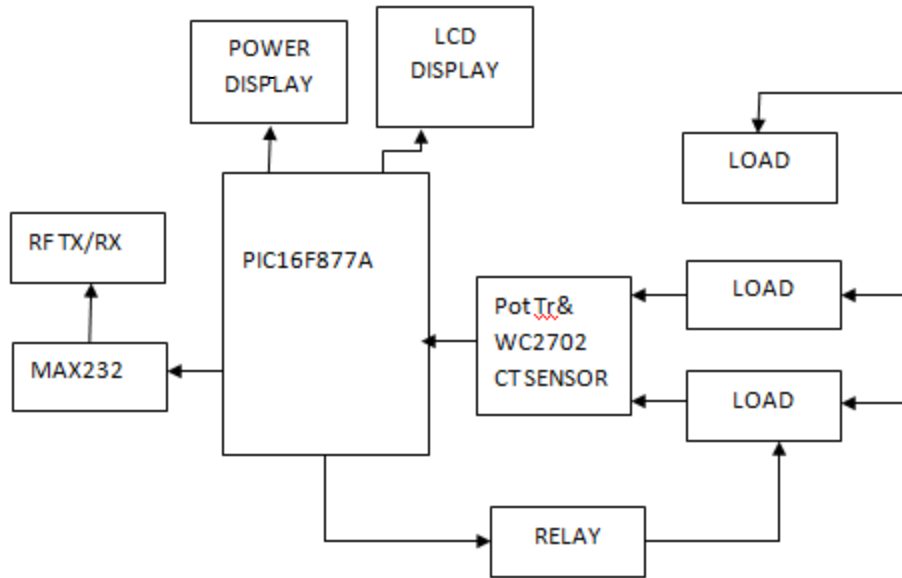

Fig3.1.Receiver side

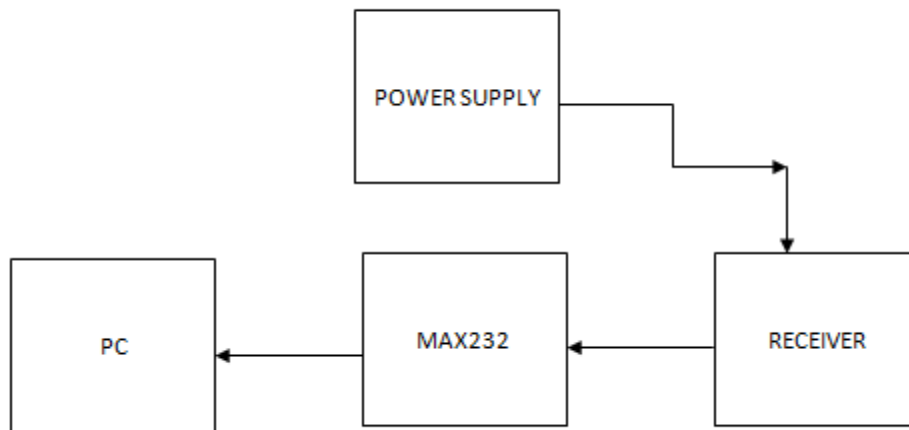

Fig3.2.Transmitter side

If the electronic device is portable, then one or more batteries are usually needed to provide the DC voltage required by electronic circuits. But batteries have a limited life span and cannot be recharged. So the solution is converting the alternating current loss hold line voltage to a DC voltage source.

3.2WCS2702:

The WCS2702 provide valuable solution for both DC and AC current sensing in industrial and communications systems. It finds application in controlling motor, management of load and fault detection.

The WCS2702 comprises hall sensor IC with temperature compensation circuit and internal conductor resistance. This low resistance can reduce power loss, operating temperature and improve the reliability. The integrated Hall IC is used to sense the magnetic field generated by the current flowing through the conduction path. The sensor leads are electrically isolated from the terminals of the conductive path. This made the need of WCS2702 current sensor to be used in applications requiring electrical isolation where opto-isolators are not required which is an costlier one.

3.3 PIC 16F877A Microcontroller:

PIC is the advancement of Harvard architecture microcontrollers and it was developed from PIC1650. The name PIC depicts Peripheral Interface Controller. Previously for program storage PIC make use of either read-only memory or field-programmable EPROM with some provisions for erasing memory, but nowadays for an program storage flash memory may also be used, and this one allow the PIC to reprogram itself. MAX232 can be a driver or an receiver, here EIA 232 voltage levels from a single 5v is supplied because of incorporating capacitive voltage regulator. The EIA-232 is converted to 5v TTL/CMOS levels using the receiver. The

TTL/CMOS input levels are converted into EIA-232 levels using driver convertor. H=high level, L=low level.

In this circuit the microcontroller transmitter pin is connected in the MAX232 T2IN pin which converts input 5v TTL/CMOS level to RS232 level. Then T2OUT pin is connected to receiver 9 pin D type serial connector will be directly connected to PC.

In PC the transmitting data is given to R2IN of MAX232 through 9 pin which is an transmission pin D type connector converts RS232 level to an 5v TTL/CMOS level. The R2OUT pin is connected to microcontroller receiver pin. In this way the data is transmitted and received between the PC and microcontroller or with other devices .

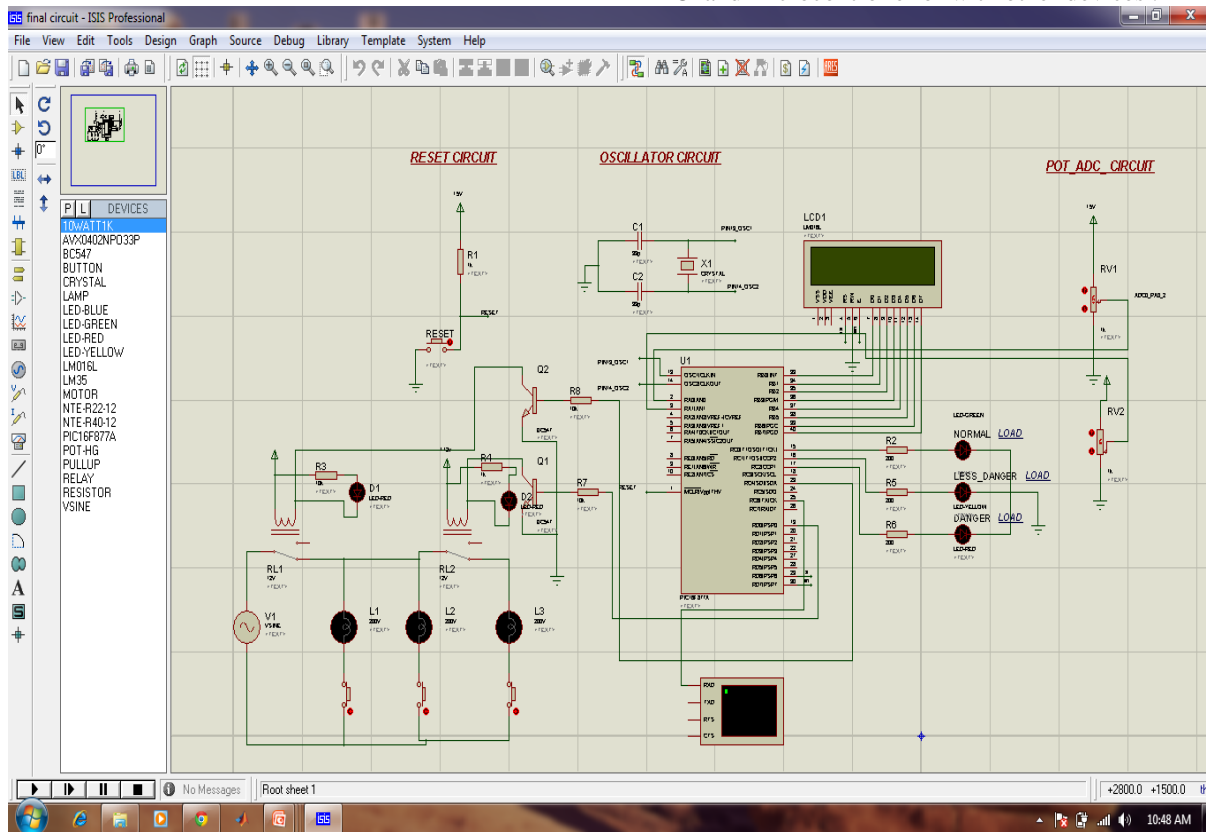

Fig 3.3.Circuit Diagram

INPUT TIN	OUTPUT TOUT
L	H
H	L

INPUT TIN	OUTPUT TOUT
L	H
H	L

Table3.1. Function Tables for Driver and Receiver

3.4 Features of MAX232:

- It exceeds TIA/EIA-232-F and ITU Recommended V.28
- It operates from a single 5-V Power Supply with 1F Charge-Pump Capacitors
- It can operate up to 120 Kbit/s
- Two Drivers and Two Receivers
- ±30-V Input Levels
- Low Supply Current : 8 mA Typical
- ESD Protection Exceeds JESD 22
- 2000-V Human-Body Model (A114-A)
- Upgrade With Improved ESD (15-kV HBM) and 0.1F Charge-Pump Capacitors
- Available With the MAX202

application scenario matures, it is believed that it will be going to be an good foundation laid and can be useful for adding new solutions for emerging threats.

REFERENCES

1. H. Sui, H. Wang, M.-S.Lu, and W.-J. Lee, "An AMI system for the deregulated electricity markets," IEEE Trans. Ind. Appl., vol. 45, no. 6, pp. 2104–2108, Nov. 2009.
2. A. Snyder and M. Stuber, "The ANSI C12 protocol suite—Updated and now with network capabilities," in Proc. Power Syst. Conf., Adv. Meter., Protect., Control, Commun. Distrib. Resour., Mar. 2007, pp. 117–122.
3. N. Muthukumar, 'Analyzing Throughput of MANET with Reduced Packet Loss', Wireless Personal Communications, Vol. 97, No. 1, pp. 565-578, November 2017, SPRINGER.
4. Muthukumar. N and Ravi. R, 'Hardware Implementation of Architecture Techniques for Fast Efficient loss less Image Compression System', Wireless Personal Communications, Volume. 90, No. 3, pp. 1291-1315, October 2016, SPRINGER.
5. P.Russell and C. Benner, "Intelligent systems for improved reliability and failure diagnosis in distribution systems," IEEE Trans. Smart Grid, vol. 1, no. 1, pp. 48–56, Jun. 2010
6. Muthukumar. N and Ravi. R, "The Performance Analysis of Fast Efficient Lossless Satellite Image Compression and Decompression for Wavelet Based Algorithm", Wireless Personal Communications, Volume. 81, No. 2, pp. 839-859, March 2015, SPRINGER.
7. Muthukumar. N and Manoj Kumar. B, 'Design of Low power high Speed CASCADED Double Tail Comparator', International Journal of Advanced Research in Biology Engineering Science and Technology, Vol. 2, No. 4, pp.18-22, June 2016.
8. Muthukumar. N and Keziah. J, 'Design of K Band Transmitting Antenna for Harbor Surveillance Radar Application', International Journal on Applications in Electrical and Electronics Engineering, Vol. 2, No. 5, pp. 16-20, May 2016.
9. C. Bennett and S. Wicker, "Decreased time delay and security enhancement recommendations for AMI smart meter networks," in Proc. ISGT, 2010, pp. 1–6.
10. Muthukumar. N and Ravi. R, 'VLSI Implementations of Compressive Image Acquisition using Block Based Compression Algorithm', International Arab Journal of Information Technology, vol. 12, no. 4, pp. 333-339, July 2015.
11. Muthukumar. N and Ravi. R, 'Simulation Based VLSI Implementation of Fast Efficient Lossless Image Compression System using Simplified Adjusted Binary Code & Golomb Rice Code', World Academy of Science, Engineering and Technology, Volume. 8, No. 9, pp.1603-1606, 2014.
12. Muthukumar. N, Ravi. R and Ruban Kingston. M, 'A Novel Scheme of CMOS VCO Design with reduce number of Transistors using 180nm CAD Tool', International Journal of Applied Engineering Research, Volume. 10, No. 14, pp. 11934-11938, 2015.
13. Akhil. M.S and Muthukumar. N, 'Design of Optimizing Adders for Low Power Digital Signal Processing', International Journal of Engineering Research and Applications, Vol. 5, pp. 59-65, March 2014.
14. Muthukumar. N and Ravi. R, 'Quad Tree Decomposition based Analysis of Compressed Image Data Communication for Lossy and Lossless using WSN', World Academy of Science, Engineering and Technology, Volume. 8, No. 9, pp. 1543-1549, 2014.
15. C. Bennett and D. Highfill, "Networking AMI smart meters," in Proc.IEEE Energy 2030 Conf., Nov. 2008, pp. 1–8.



P. Venkateswari was born in Tirunelveli, Tamilnadu, India, in 1994. She received the B.E (Electronics and Communication Engineering) from Francis Xavier Engineering College, Tirunelveli. She currently pursuing her Post Graduate programme in Communication System from Francis Xavier Engineering College. Her major research interests are Embedded system, Signal and Image Processing.