

Saw Gin Accelerator

¹Kurbanov Dilmurat Maripjanovich, ²Umarov Akmal Akparalievich, ³Akhmedkhodjaev Khamit Tursunovich, ⁴Kenjaeva Muazzam Isroil Qizi.

¹Assistant of the department "Technology of primary processing of natural fibers" Namangan Institute of Engineering and Technology. Republic of Uzbekistan, Namangan. E-mail: gurbonov.dil@mail.ru

²PhD, Senior teacher, Department of "Technology of primary processing of natural fibers" Namangan Institute of Engineering and Technology. Republic of Uzbekistan, Namangan. E-mail: akmal.umarov@mail.ru

³Professor of "Technology of primary processing of natural fibers", Doctor of Technical Sciences Namangan Institute of Engineering and Technology. Republic of Uzbekistan, Namangan.

⁴Assistant of the department "Technology of primary processing of natural fibers" Namangan Institute of Engineering and Technology. Republic of Uzbekistan, Namangan.

Annotation: *The article provides a literary review on the design of the saw gin roll box and the regulation of the density of the seed roll. On the basis of the studied, a new design of the roll box of the saw gin is proposed, which will ensure a uniform supply of cotton depending on the density of the seed roll.*

Keywords: *The Cotton, Saw Gin, Seed, Fiber, Saw, Roll Box, Seed Roll, Quality, Efficiency, Productivity, Density, Accelerator.*

I. INTRODUCTION

Currently, in the cotton ginning industry of the CIS countries, gins of the DP series are most widely used, which have fairly good technological indicators. But the problem of regulating the density of the seed roll has not been completely solved [1].

Maintaining the optimum density of the seed roll is the most important technological and economic task that can be solved by adjusting the speed of the electric drives of the gin feeders. To solve this problem, a regulator is proposed in the work [2].

The study [3] presents the results of experiments on manual and automatic control of the feed roll speed in order to uniformly control the density of the seed roll, as well as to determine the dependence of the fiber and seed quality during automatic feeding, depending on the load of the saw cylinder in the saw gin.

With an increase in the density of the seed roll in the roll box of the saw gin, the quality indicators of fiber and seed deteriorate, energy consumption increases, machine breakdowns increase, and with a decrease in density, the performance of the saw gin decreases. Therefore, control of the density of the seed roll is one of the important problems in the fiber separation process.

II. MATERIAL AND METHODS

In [4], it is proposed to change the speed of rotation of the saw cylinder with a decrease in the diameter of the saws to maintain their linear speed, and thereby preserve the density of the seed roll and the productivity of the machine. The article describes the problem of regulating the density of a seed roll in a saw gin of the DP series, provides an overview of work on regulating the operation of the machine, determines the dependence of the productivity of gins and linters on the state of the saw system in these machines, as well as changes in the linear speed of the saw by changing its diameter. The critical speed of the gin and linter saw cylinder was also determined to prevent resonance. In this case, the Simulation package of the SolidWorks computer program was used. The results of the study made it possible to use the speed control of the saw cylinders when changing the saw diameter, which will increase the productivity of the machine while maintaining the quality of the fiber and seed.

The article contains information about saw gin used at cotton processing plants. The influence of the density of the seed roll, which is formed in the roll box of the saw gin, on the load of the saw cylinder drive and on the technological characteristics of the machine is considered. As a result of the research, in order to preserve the quality characteristics of fiber and seeds, the author proposes a gin stand with a system for regulating the position of the roll box [5].

In the article stake accelerator has proposed on the side of the roll box in order to increase the productivity of the gin machine. The effect to the raw material of the proposed stakes was studied. Movement differential equation of the seed roller was made up and necessary graphics were taken based on laws [6].

The article describes the research process of ginning, conducted at the stand of the saw gin of the DP series. The analysis of the roll box of saw gins of different companies was carried out, given the results of studies to determine the speed and density of the seed roll in the roll box of the saw gin. A diagram is given for the dependence of the speed of the feed rollers on the incoming signal [7].

The article analyzes and studies the improved types of gin equipment at cotton processing enterprises and the principle of their work. The device accelerates the movement of raw materials and increases production efficiency [8].

The research work is focused on studying the influences to velocities of the rotation of the platen and corner of the deflection to lines, connecting centre of the platen and ware of the cylinder from vertically, on contact power of the interaction raw material roll with by cylinder [9].

III. RESULTS

On the basis of [10] gins 3HDDM and 4DP-130, a new gin under the brand name DPZ-180 was designed and manufactured with two 90 sawing cylinders along the length of the roll box as in 3HDDM. Roll box 4DP, divided into two separate roll boxes along the length of 3HDDM, allows you to repair one roll box without stopping the ginning process of the other.

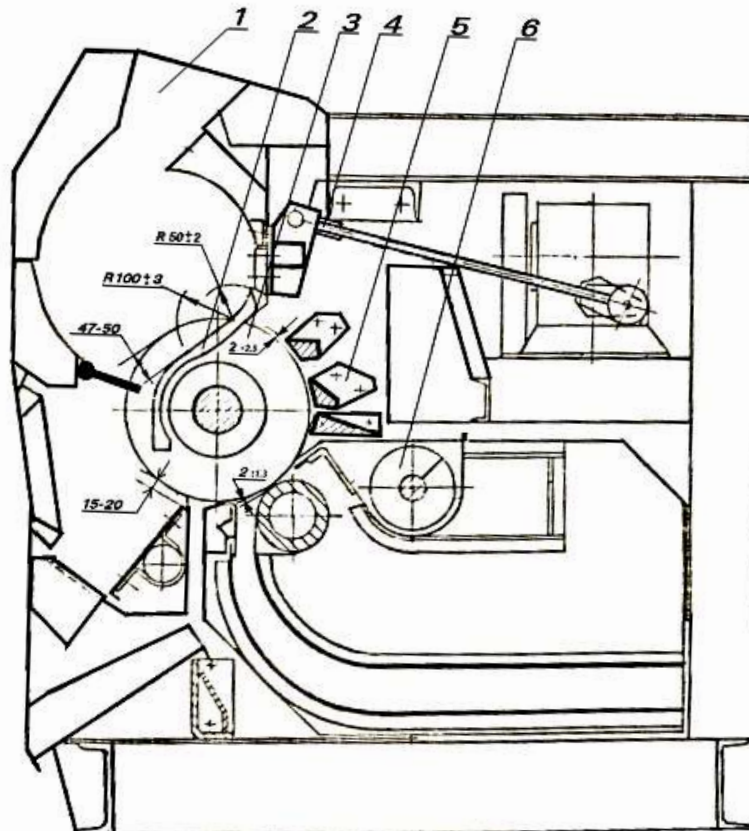

Fig. 1. Sawing gin scheme 5DP-130

1 – roll box of gin; 2 – grate; 3 – saw cylinder; 4 – mechanism for moving the roll box; 5 – trash grate; 6 – trash conveyor

From the technological scheme of the work of domestic gins it can be seen (Fig. 1) that the direct supply of raw cotton to the saw cylinder is carried out through the seed roll, which creates additional power losses up to 12.3 kW, that is, excessive loads on the saw blades and grates. As a result, the resource of grates and saw blades is reduced, while the amplitude of bending vibrations of the saw cylinder shafts reaches 6 mm.

On the sidewalls of the roll box of the new gin [11, 12], a rotating disk is installed for rotating the seed roll in order to reduce its density. These processes have been practically investigated. With an increase in the density of the seed roll, its friction against the surface of the roll box increases, this leads to a decrease in the rotation speed, a decrease in productivity, and a deterioration in the quality of fiber and seeds. In this case, additional rotating discs forcibly rotate the seed roll and stabilize its speed and density.

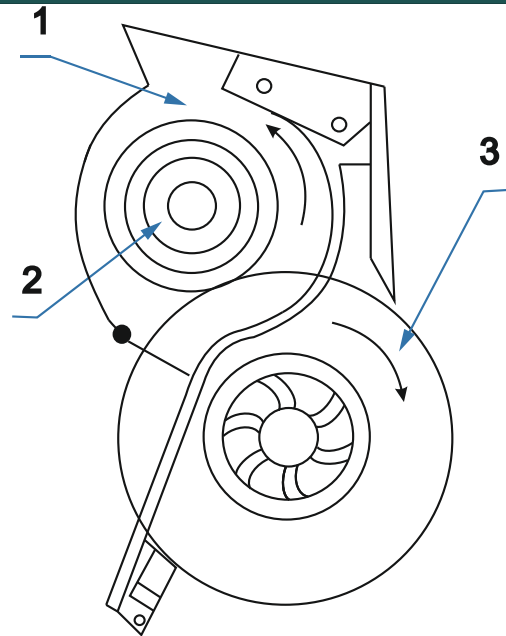

Fig. 2. Scheme of a gin with a seed roll accelerator
1 – roll box, 2 – rotating disc, 3 – saw cylinder

The new proposed device (Fig. 3) an accelerator for a saw gin with a system for regulating the density of a seed roll consists of a front apron 1, a front bar 2, a grate 3, a saw cylinder 4, a seed comb 5, a lower apron 6, feed rollers 7, an electric motor for accelerator 8, frequency converter 9, accelerator 10, electric motor for saw cylinder 11 and load current sensor 12. The saw cylinder shaft is connected to an electric motor shaft, which is provided with a load current sensor. The accelerator motor is connected to a frequency converter. When the density of the seed roll changes, the load on the saw cylinder changes and, thus, the load current sensor sends a signal to the frequency converter of the accelerator motor.

Providing the electric motor with a load current sensor allows the accelerator to be adjusted, as well as to control the density of the seed roll in the roll box.

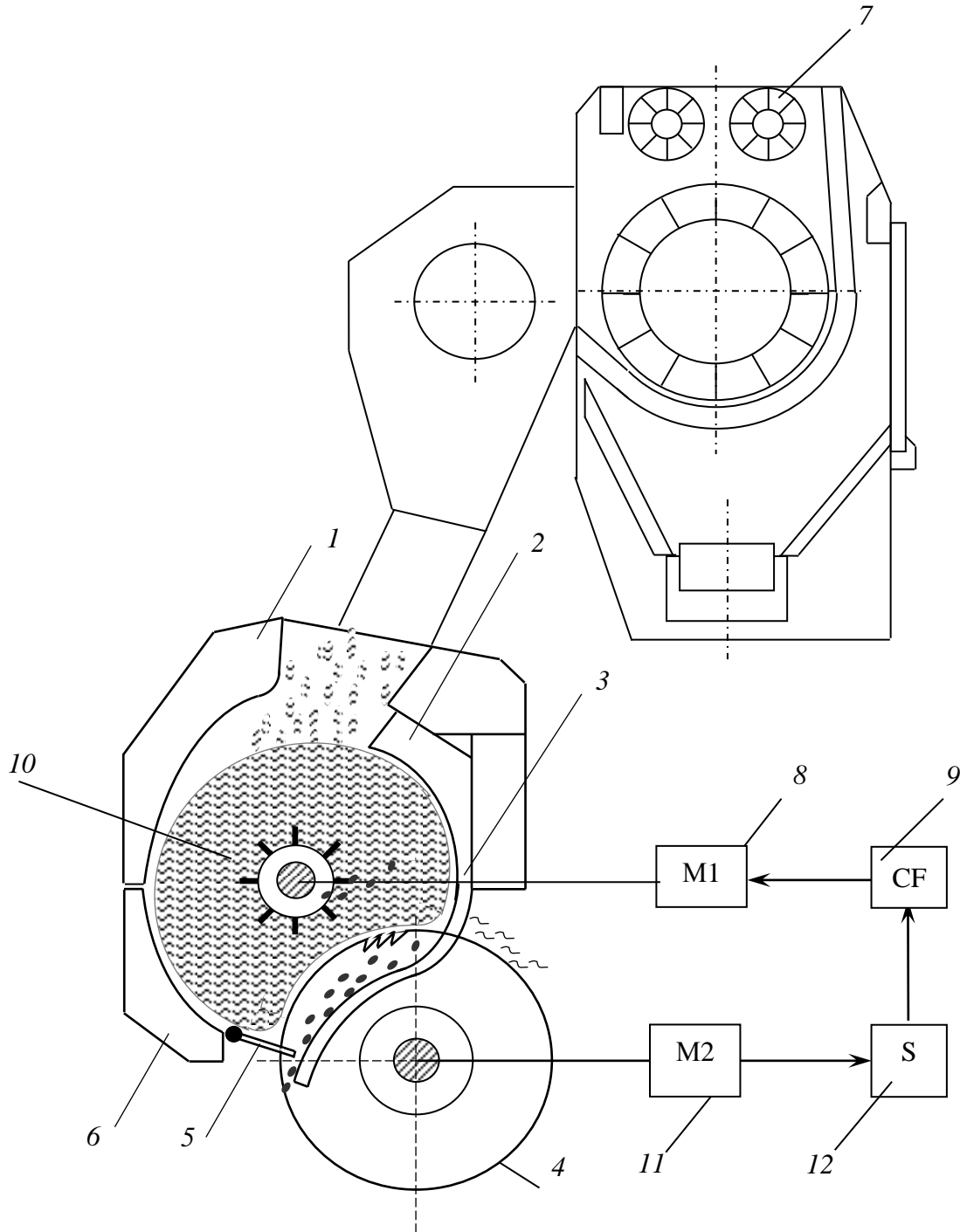

Fig. 3. Saw gin accelerator:
 1 – apron, 2 – front bar, 3 – grate, 4 – saw cylinder, 5 – seed comb, 6 – lower apron,
 7 – feed rollers, 8 – electric motor for accelerator, 9 – frequency converter,
 10 – accelerator, 11 – electric motor for saw cylinder, 12 – load current sensor

Saw gin with an accelerator works as follows. The cotton entering the roll box contacts the saw cylinder 4 and forms a seed roll. The separated fiber with the help of the saw cylinder 4 passes through the grate 3 and is removed from the roll box. Seed output is regulated by a seed comb 5.

IV. DISCUSSIONS

When the density of the seed roll changes and, accordingly, the load current of the electric motor 11 of the saw cylinder 4 changes, the load current control sensor 12 reacts, which controls the frequency converter 9 of the electric motor 8 of the accelerator 10. The frequency converter 9 changes the rotation speed of the accelerator motor 8 by changing the frequency of the current. Thereby, it changes the volume of supplied cotton so that the optimum density of the seed roll is restored.

References

1. A.Umarov. Investigation of the density control of a seed roll at the gin. Natural and technical sciences®. Natural and technical sciences®. Moscow, 2008. – № 2 (34). 333-334.
2. M.A. Abduvakhidov, A.A. Umarov. Research of speed regulation of electric drives of gin feeders. Natural and technical sciences®. - Moscow, 2008. - No. 2 (34). 328-329.
3. Umarov A.A., K. Ortikova, A.U. Sarimsakov, D. Kurbanov. Analysis of the control of manual and automatic regulation of the saw gin feed rollers. Scientific journal "Universum: technical sciences". Part 2. Moscow, 2020. - 9 (78). 22-26. <https://7universum.com/ru/tech/archive/item/10693>
4. Umarov A., Ortikova K., Sarimsakov A. Analysis of Speeds of Cylinders of Saw Gins and Linters and Determination of Critical Frequencies for them. Scientific Research Publishing, Engineering, 2020, 12, 715-722. DOI: [10.4236/eng.2020.1210050](https://doi.org/10.4236/eng.2020.1210050).
5. Umarov A., Akhmedkhodzhaev Kh., Sarimsakov A., Kenjaeva M. The Saw Gin Stand with Adjustable Movement of the Roll Box. Scientific Research Publishing, Engineering, 2018, 10, 486-494. <http://www.scirp.org/journal/eng>, <https://doi.org/10.4236/eng.2018.108034>.
6. Sarimsakov A., Muradov R., Umarov A., Kurbanov D. Movement Differential Equation of Seed Roller which Has Been Installed Stake Accelerator on the Roll Box of Gin Machine. Scientific Research Publishing, Engineering, 2018, 10, 521-529. <http://www.scirp.org/journal/eng>, <https://doi.org/10.4236/eng.2018.108038>.
7. Kh.Axmedxodjayev, A.Umarov, K. Ortiqova. Investigation of the Ginning Process on ДП Series Saw Gin Stands. Scientific Research Publishing, Engineering, 2019, 11, 523-530 <http://www.scirp.org/journal/eng>.
8. A.U. Sarimsakov, D. M. Kurbonov, Sh., H. Halikov. The study of the crucible rotation of raw materials with a practical way. Scientific and practical journal "Economy and Society" No. 12 (67) -2019 (December) https://iupr.ru/nauchno_prakticheskij_zhurnal_ekonomika_i_socium_12_67_2019_g_dekabr/.
9. A.Sarimsakov, R.Muradov, B.Mardonov. Modeling Of the Process of Interaction of the Saw Cylinder with the Raw Material In The Process Of Ginning. Published by: The Mattingley Publishing Co., Inc. May-June 2020. ISSN: 0193-4120 Page No. 27386– 27391.
10. D.M.Mukhammadiev. "Dynamics of machine units of saw gin with seed retractor system and condenser with pulse air stream" dissertation on the scientific degree competition of the doctor of sciences in technical. Tashkent-2014. 25 page.
11. Sarimsakov A., Karimov A., Mardanov B. Generation as an aspect of the technological process // International Journal of Experimental Education. - 2015. - No. 11.
12. Mardonov B.M., Sulaimonov R.Sh., Sarimsakov A.U. Study of rotational motion of cylindrical layer of grain medium // Materials Science. - 2015. - No. 3. - P. 36-41.-6. - P. 948-951.