

The Design and Fabrication of a Horizontal Hand Baler

Kotingo Kelvin¹, Dio Ambakederemo Wenapere² and Agonga Oyinbonogha Fred¹

¹Department of Mechanical Engineering, Niger Delta University, Wilberforce Island, Bayelsa State, Nigeria

²Department of Agricultural and Environmental Engineering, Niger Delta University, Wilberforce Island, Bayelsa State, Nigeria

Abstract: The horizontal hand baler is a press machine used to make dry materials more compact by the application of steady force against the material placed in a forming box, from one end while the other end is fixed. Therefore, the design and construction of a manual baling machine for rectangular bales is studied and fabricated in this study. The materials used for the construction are handle, forming box, plunger, end plates and support frames. The bending moments, shear force, mass and density of the bales were calculated in the design calculations. The force required to push the compression plate is 600N while the density of the bale was found to be 187.5 kg/m³. After design implementation of the baler, a performance tests carried out which showed that the baler met its design objectives by making bales of the required dimensions and density. The cost of production is cheaper when compared to foreign baler machines. The horizontal baler was produced at a cost of 28,100 naira. It was recommended that future designs should be made of plain carbon steel or toughened cast iron instead of wooden material due to vibration and pressure factors that may be encountered during its operations.

Keywords: Compression, Horizontal Hand Baler, Recycling, Slider Mechanism, Bins, Crank, Density, Mass, Shear Force & Bending Moment Diagram

INTRODUCTION

A baler machine is a useful piece that can be used for recycling purposes. It is more or less a press primarily used for the compression of waste materials, such as cardboard, paper, soft plastics and other materials such as hay and fabrics, usually tied together to create a bale. Baler machines are primarily used to deal with waste cardboard and soft plastic; but they are also flexible enough to bale more bespoke materials such as carpet, cans and hard plastic. Balers are a solution to having bins on site emptied and reused. (Cardboard Balers, 2016).

The horizontal hand baler is a machine used to make dry materials more compact by the application of a steady force against the material in question from one end while the other end is fixed. The material to be compressed is usually contained in a forming box and the force is applied along the horizontal axis. The mechanism that best suits this purpose is a slider crank mechanism. The most common and essential use of a crank and slider mechanism is found in an internal combustion engine. It is the mechanism behind the rotation of the internal combustion engine, this mechanism can also be found in some windows which are operated using links and pin joint. Basically a slider crank mechanism converts reciprocating motion to rotational motion by virtue of force and moment. The basic principle of this mechanism is that as the slider moves back and forth it pushes the connecting rod link which then transfer the force to the crank link and the crank shaft then exhibits a rotational motion due to the moment applied by the crank (Martins, 2018).

The slider crank mechanism is an arrangements of mechanical parts designed to convert straight-line motion to rotary motion, as in a reciprocating piston engine, or to convert rotary motion to straight line motion, as in a reciprocating piston pump

OBJECTIVES

1. To design and fabricate a baling machine at minimum and low maintenance cost
2. To design a baler that will be easy to operate and at the same time durable.
3. To be able to create bales of materials such as; paper, textile, wood shavings and even hay.

MATERIALS AND METHODS

The basic material employed for the construction of the hand baler was wood (plywood and hardwood), the only exception is the connecting rod which is made up of iron metal. Wood was chosen because of its low cost, availability, suitability for the range of application. The parts of the hand baler and their descriptions are given as follows:

- i. Handle (crank): The cross sectional area of the handle is 20mm x 40mm along the straight part
The total length of the handle is 909mm. Along the length of the handle 2 holes are drilled. The handle is joined to both the plunger and the frame by the means of a bolt and nut system through the drilled holes. The joints are not taut, to enable the mobility of the system

ii. Plunger: The plunger is made up of two parts which are basically two links of the conventional slider crank mechanism. The first parts which is similar to a connecting rod, is made up of two metal bars each of 10mm thickness and lengths of 336mm. the bars are attached to the handle by means of bolt and nuts. The bars are also joined to the second part of the plunger which is the moving plate. The plate is essentially a box of length 90mm

iii. Forming Box The forming box is a part of the frame. This is where the baled material assumes its final shape after compression. Since it is just an extension of the frame, it has the same cross sectional area as the frame and a length of about 300mm to 400mm, depending on the size of the bale and the position of the end plate. Other materials used are end plate 30mm thickness , support frame 15mm thickness and base.

Design Calculations

Mass properties of baler are stated as follows:

Mass = 13.56 kilograms

Volume = 0.01 cubic meters

Surface area = 2.10 square meters

Center of mass: (meters)

$$X = 0.01$$

$$Y = 0.43$$

$$Z = 0.66$$

Principal axes of inertia and principal moments of inertia: (kilograms * square meters)

Taken at the center of mass.

$$I_x = (0.73, 0.05, -0.68) \quad P_x = 0.27$$

$$I_y = (-0.04, 1.00, 0.03) \quad P_y = 1.72$$

$$I_z = (0.68, 0.00, 0.73) \quad P_z = 1.84$$

Moments of inertia: (kilograms * square meters)

Taken at the center of mass and aligned with the output coordinate system.

$$L_{xx} = 0.99 \quad L_{xy} = 0.05 \quad L_{xz} = -0.78$$

$$L_{yx} = 0.05 \quad L_{yy} = 1.71 \quad L_{yz} = -0.05$$

$$L_{zx} = -0.78 \quad L_{zy} = -0.05 \quad L_{zz} = 1.12$$

Moments of inertia: (kilograms * square meters)

Taken at the output coordinate system.

$$I_{xx} = 9.40 \quad I_{xy} = 0.12 \quad I_{xz} = -0.68$$

$$I_{yx} = 0.12 \quad I_{yy} = 7.67 \quad I_{yz} = 3.77$$

$$I_{zx} = -0.68 \quad I_{zy} = 3.77 \quad I_{zz} = 3.57$$

The shear force and bending moment diagram of the baler assuming a 200N force is applied to the handle and the body has a uniformly distributed 50N load is shown;

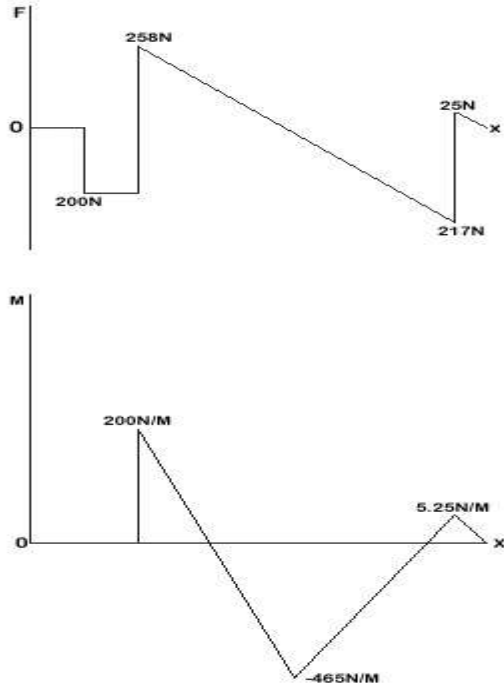

Figure 1: bending moment & shear force diagram

Results and Discussions

Lever Analysis

Let the force required to push the compression plate be P, while the force applied to the lever handle be F.

Let the distance between pivot and the handle be given as x and the length of the connecting rod is given as l, then from lever principle the force required to push the plate is given as;

$$P = \frac{Fx}{l}$$

Since the x is bigger than l the value of P becomes larger than F.

For example, if the force applied to the lever handle is 200N and the ratio of the length of handle to the length of connecting rod is 3, find P.

Solution

$$P = \frac{Fx}{l}$$

$$P = (200 \times 3) \text{ N}$$

$$P = 600 \text{ N.}$$

Power of Lever Arm

The work done by the ram is given by the force (P) multiplied the distance travelled by the ram(D), mathematically;

$$W = PD$$

But, $P = \frac{Fx}{l}$

Therefore $W = FxD/l$

Let t be the time it takes the ram to travel through D, therefore the power of the lever arm can be given by;

$$P = Wt$$

Density of Bale

The baler was tested with dry wood shavings. The mass of the baled material was 3kg. The size of the bale was 0.4m x 0.2m x 0.2m (volume= length x width x height).

We know that, $\rho = m/v$ where,

P = mass density of material

M =mass of bale

V =volume of bale

Therefore, the density of the bale is;

$$(3/0.4 \times 0.2 \times 0.2) \text{ kg/m}^3$$

$$= 187.5 \text{ kg/m}^3.$$

Table 1: Bill of Quantities

Component	Quantity	Price, NGN
Plywood	1.4m * 1.4m	5000
Bolt and nut	3	150*3 = 450
Rope	15 meters	150
Iron bar	2	750*2 = 1500
Roller bearings	2 pairs	1500*2 = 3000
Nails	1 packs	500
Wood glue	1 unit	1500
Hard wood	1 plank	1000
Man power	1	15000
Total Cost		28,100 NGN

ACKNOWLEDGEMENT

I wish to express my profound gratitude to God Almighty for the grace, strength and wisdom he gave to me throughout this study. My gratitude also goes to my mentor, Engr. Prof. Emmanuel Adigio and the staff of the Department of Mechanical Engineering, Niger Delta University for their tremendous support for this research work. May God bless them abundantly.

CONCLUSION AND RECOMMENDATIONS

A horizontal hand baling machine has been successfully designed and produced that has a slider mechanism with minimum labor and material cost price of 28100 naira. The performance of the machine is of acceptable standard. The machine has been designed in such a way that it meets with the requirements of the aim and objectives of the study. If produced on a larger scale, the cost would be even more minimal, thus bringing more profit to the investors and manufacturers

After design implementation and fabrication of the baler, some tests were carried out on the baler. Results showed that the baler was able to make bales of the required dimensions and density. The produced machine would be of immense benefit to the agricultural and recycling sector if the results obtained in this paper are improved upon and supported by the government or multinationals.

RECOMMENDATION

The project was put together within the limits of financial and material constraints. Being a pilot project there is much room for improvement in the overall design of the baler. Future designs should be made of plain carbon steel or toughened cast iron instead of wooden material. This will enable the baler to withstand pressure and vibration when fully operational. Therefore it is recommended for large and commercial scale production to help bring financial gains to investors.

REFERENCES

Advameg, Inc., 2019. Hay Baler. [Online] Available at: <http://www.madehow.com/Volume-2/Hay-Baler.html>[Accessed 12 March 2019].

Carlo Ferraresi, W. F. a. G. Q., 2017. Design of human powered balers for straw bale construction in developing countries: A case study of Haiti, Turin: Springer.

Kevin, S. M. & Levi, T., 2001. Wind guard for round baler. Food Waste and Sustainable Food Waste Management in the Baltic Sea Region, Volume Vol. no. 11.

Martins, E., 2018. Martinsmechanics. [Online] Available at: www.steemit.com

[Accessed 18 March 2019].

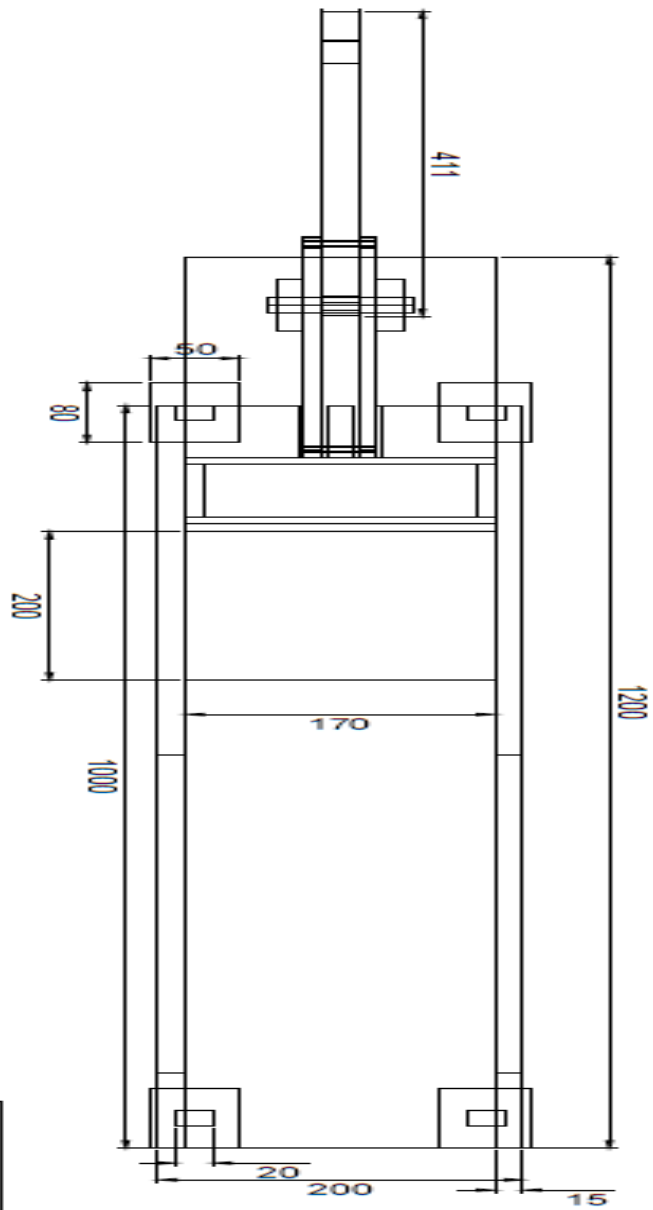

DEPARTMENT	MECHANICAL ENGR
DESIGNED BY	OGIBAH ESRI
DRAWN BY	ABODE BENJAMIN
SUPERVISOR	ENGR. K. KOTINGO

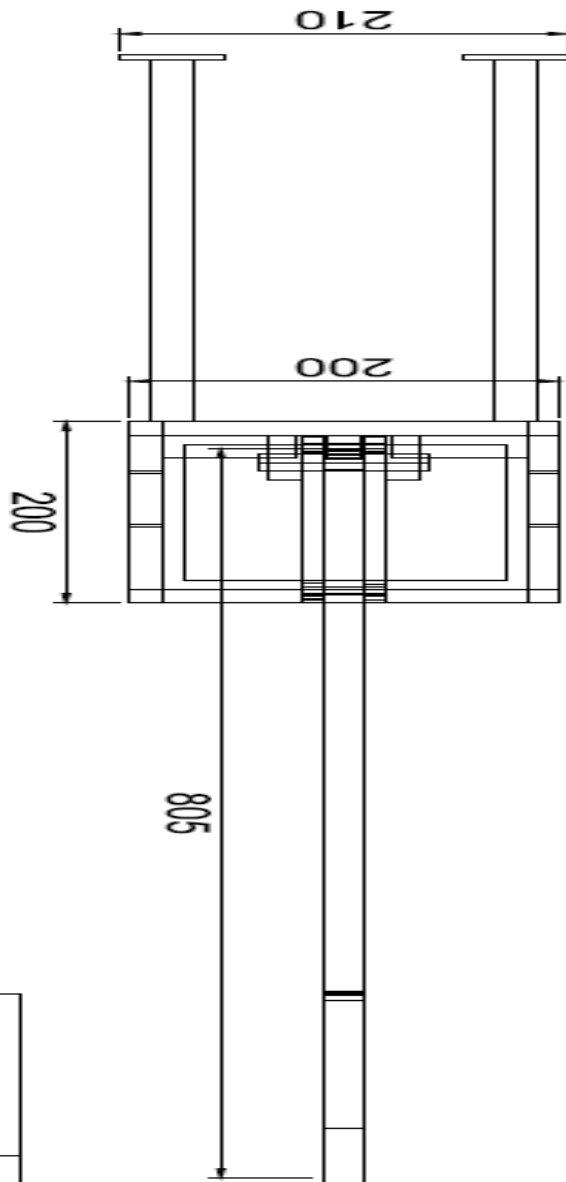

DEPARTMENT	MECHANICAL ENGINEERING
DESIGNED BY	OGIGBAH ESIRI
DRAWN BY	ABODE BENJAMIN
SUPERVISOR	ENGR. K. KOTINGO

