

Study on Wireless Power Transfer for Stationary and Dynamic Charging Systems for Electric Vehicles Using MATLAB/SIMULINK

Ahmed M.A.A Elngar, Gunawan Dewantoro, Atyanta Nika Rumaksari

Satya Wacana Christian University

612019901@student.uksw.edu

Highlight: This research aims to conduct simulations of powering electric vehicles and wirelessly transfer electricity in static (stationary) and dynamic (in motion) positions. The author imagines that this emerging technology enables vast benefits in mass public transport, especially in megacities like Cairo and Jakarta, which are already suffering from the effects of urban pollution and mass overcrowding. This study investigates further the ability of a vehicle to move in a steady motion while charging, allowing the vehicle to travel further distances without the need to stop (for instance, to charge in stations or when loading or unloading passengers or goods).

Abstract: *Electrified transportation will minimize greenhouse gas emissions while lowering dependency on fossil fuels. To encourage the adoption of electrified transportation, a number of charging networks must be built in a user-friendly workplace. Wireless electric vehicle charging systems WEVCS could be a viable mechanism for charging electric vehicles (EVs) without needing a fixed charging cable. The present state of wireless power transfer technology for electric vehicles is described in this study. It also contains components for wireless transformers that have been researched with a range of ferrite shapes. WEVCS are linked to health and security and welfare concerns, which have been examined in relation to current international standards development. The static and dynamic WEVCS applications are explained and documented, demonstrating the recent advancement using characteristics derived from research labs, universities, and companies. Future WEVCS possibilities, like “vehicle-to-grid (V2G)” and “in-wheel” wireless charging systems WCS, are also investigated and compared to other advanced techniques on a qualitative level.*

Keywords: Electromagnetic Connection, Wireless power transfer, Wireless electric vehicle charging system, MATLAB/SIMULINK.

1- Introduction

Since Guglielmo Marconi's (1874–1937) development of long-distance radio transmission, wireless communications technology has been widely available [1], and wireless communication technologies have become integrated into our daily lives. Wireless communication has become an indispensable part of everyday life where most contemporary individuals can't picture living without a mobile phone or a laptop computer. The technical advancement of energy storage systems is also acknowledged for the achievement of wireless communication innovation. People desire more time without being tethered. At the same time, they want better technological equipment. The rising demand for mobile gadgets with high computational power prompted the development of lithium batteries with high energy density. However, a new wireless revolution is on the horizon that will eliminate the final line for power transfer. The study of Tesla Tower by Nikola Tesla (1856–1943), who aimed to send electricity via a waveguide between the earth's surface and the ionosphere in the early 1900s, inspired the idea of wireless power transmission [1, 2, 3].

Despite the fact that the experiment was not particularly successful at the time, research on wireless power transfer technology continued, and various applications were developed. Wireless Charging Systems WCS have been suggested for high-power devices such as EVs and connected electric vehicles in static modes. WCS can provide more benefits in terms of simplicity, dependability, and user-friendliness than plug-in charging solutions.

2- Electric vehicle (EV) wireless charging system

2.1 The Fundamental Concept of Functioning

Fig. 1 illustrates a typical block chart of the stationary WCS for EVs. AC signal is generated from an AC generator then converted to DC to cross the HF then to AC again with power correction factor using AC/DC and DC/AC converters and rectifiers, enabling power to be transferred from the emitter to the receiving coil [5]. Compensatory topologies based on series and parallel combinations are provided to improve overall system efficiency on both the emitter and receiving sides. The receiving coil, usually located below the vehicle, transforms the fluctuating electromagnetic flux fields. The HF AC is subsequently inverting to a steady DC source that the on-board batteries may utilize. The power management, telecommunications, and battery management systems (BMS) are integrated to

minimize health or risk problems and guarantee reasonable performance. On both the emitter and receiving sides, magnetic flat ferrite plates are employed to prevent any destructive leakage fluxes and boost the magnetic flux spread.

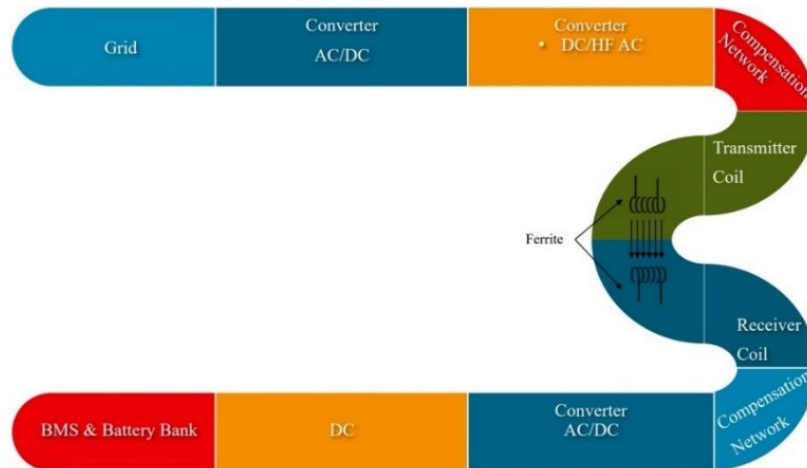

Figure 1 Stationary WCS for EVs

2.2. Methods for Transferring Electricity Wirelessly

a. **Inductive Coupling:** Coupling Induced Inductive coupling and electromagnetic power transmission is supported by a fundamental physical concept. Electricity is transmitted between both the primary and secondary through a magnetic field. Coils referred to as reception coil and transmission coil are used to construct a transformer between the secondary and primary. According to Ampere's law, an oscillating magnetic field (B) is formed when toggling voltage is utilized to the transmission coil (Tx). According to this law, the electromagnetic field travels through the reception coil (Rx), which is oriented in the same direct connection as the transmitter coil. Based on Faraday's law of electromagnetic induction, it generates a changing voltage, which creates a changing current in the receiver [6]. This type of inducting coupling transmits voltage to the set. The frequency ranges from 20 to 40 kHz.

b. **Capacitive Coupling:** The electromagnetic coupling approach, also known as capacitive coupling, employs an electromagnetic field to transmit a charge through two plates. Inductive Coupling with Resonance over 4 cm long, resonating transmission system is a power transmission mechanism. The functioning resonant frequency is 0.1 MHz to 0.2 GHz, and the efficiency is increased by 50%. It is utilized for wearable electronics when the pairing impedances are lower than 50% and reach optimal efficiency. The technique can power many gadgets at the same time. It works well at distances of a few millimeters to a few meters. Inductive Capacitive Resonance is again utilized to increase the frequency from low to mid-range via connecting with capacitive coupling.

Four alternative WEVCS design methodologies have been employed since the advent of wireless charging systems for EVs.: Conventional inductive power transfer includes inductive power transmission (IPT), capacitive wireless power transmission (CWPT), magnetic gear wireless power transmission (MGWPT), and resonant inductive power transfer (RIPT).

2.2.1. Wireless Power Transfer using Capacitance

Unlike earlier mid-range WPT approaches, Capacitive WPT is accomplished by the use of an electromagnetic current. Two aluminum plates are put in the power transmitter and receiver to operate with a capacitive WPT. As illustrated in Fig. 2, each element has one plate attached to either the transmitter or the receiver linking the power supply or the load. The plates in the transceiver are aligned in the same direction. When the two sets of plates are distant enough to each other, they function as two capacitors, closing the circuits. Respectively. Mutual coupling occurs under the conditions indicated above. As an outcome, an electromagnetic field is created between both the plates, producing an electrical charge in the electricity receiver [3]. The current generated in the electricity receiver is due to the applied shift between the two pairs of plates of the electromagnetic field, much like in the Ferro WPT. The operating frequency is raised from the electricity given by the system for the purpose of boosting this rate. This is accomplished by the use of an inverter, which creates Volts. Capacitive WPT, unlike ferro systems, may transmit data even from metal plates. In situations whereby capacitive WPT was thus evaluated, the existence of such intermediary metal plates has no effect on the development since the damage is negligible and the plates themselves do not attain an intolerable heat. The electromagnetic current is also limited to the zone dividing the two plates, which is a significant benefit. Consequently, the topic of study somehow doesn't flee from this zone, despite the fact that the electromagnetic field moved in the earlier WPT procedures. The resonant technique has proven to be matured sufficiently to handle a more significant level of power transmission with a high percentage of efficiency at the same time.

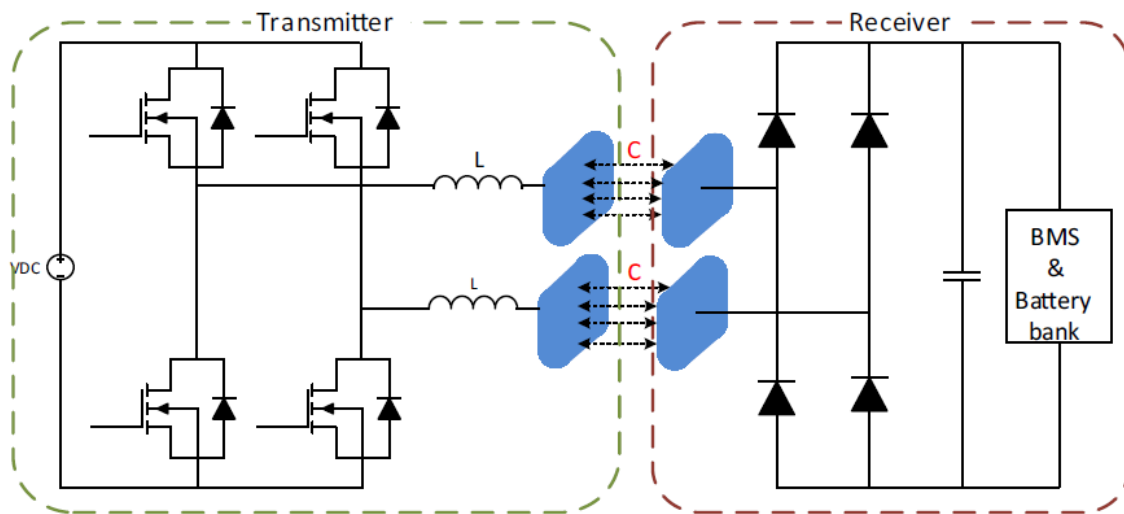

Figure 2 Capacitive Wireless Power Transfer schematic representation.

2.2.2. Magnetic Gear is used to Transmit Electricity Wirelessly.

As illustrated in Fig. 3, the magnetic gear WPT (MGWPT) differs from both the CWPT and the IPT. In this technology, two synchronized permanent magnets (PMs) are put along next to each other's, facing each other as cable founded WEVCS. The current source for the transmitter winding is the main power, which causes a typical torque on the primary permanent magnet. The primary permanent magnet rotates and generates torque on the secondary permanent magnet through mechanical interaction when the mechanical torque is used. The primary permanent magnet in a pair of synchronized permanent magnets operates in generator mode.

In contrast, the secondary permanent magnet gets power from the power converter and distributes it to the battery via the BMS. The MGWPT was designed as a laboratory prototype with a power output of 1.6 kW and a 0.150 m air gap length. Nevertheless, there are numerous difficulties in adopting this technology into both static and dynamic devices. Accordingly, actuators lost their synchronization velocity at 150 Hz, affecting the transmitted power significantly. For the purpose of dodging exceeding the upper power limit, the velocity must be constantly adjusted using the sophisticated feedback system from the battery bank to the primary side. As the coupling between the two synchronized couplings reduces rapidly, the axis-to-axis spacing within the primary and secondary permanent magnets is inversely related to the power transmission capacity. Consequently, although it may be adequate for stationary WEVCS, implementing it in real-time applications will be complex.

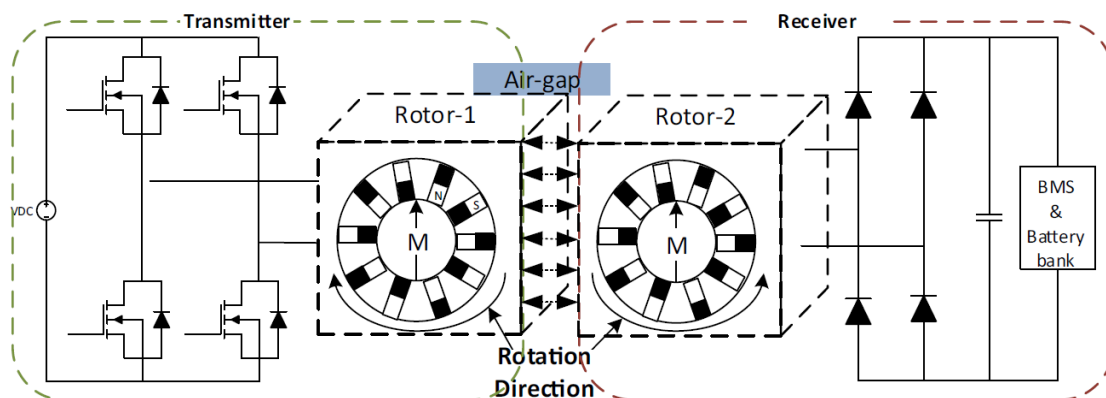

Figure 3 Magnetic gear-based WPT schematic representation.

2.2.3. Power Transmission through Induction.

Inductive power transfer (IPT) is a wireless power transfer method that utilizes a time-varying electromagnetic field within mutually coupled coils [7]. Because the quantity of power delivered is determined by the mutual coupling coefficient within the coils, IPT systems are classified as weakly or strongly coupled. Because the coupling factor (coupling coefficient) in closely linked systems is near to one, the transmitted power efficiency is relatively high. A power transformer (Fig.4) is a

typical application for close-coupled systems. The coupling coefficient in freely or weakly connected systems is lesser; contingent on the application, it may vary from 0.01 to 0.5. The vast gap within the coupled coils relative to the coil diameters and/or the lack of a sufficiently porous magnetic way linking them are the major causes of the poor coupling coefficient. Because the vile coupling coefficient affects power transfer efficiency, the receiver coil must be resonated in order to improve efficiency.

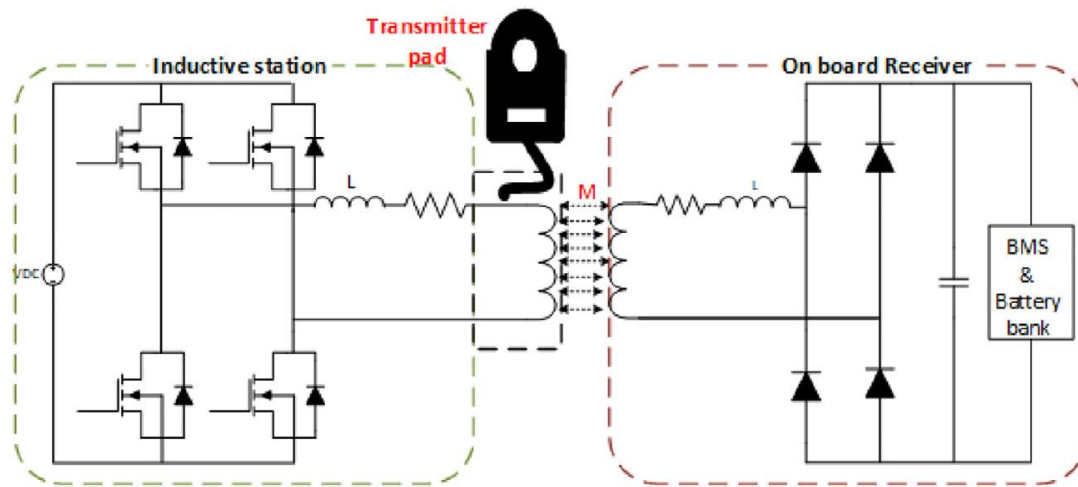

Figure 4 Traditional Inductive Power Transfer Schematic Representation

2.2.4. Inductive Power Transmission with a Resonant Frequency

$$f_{r(p,s)} = \frac{1}{2\pi\sqrt{L_{p,s}C_{p,s}}} \quad (1)$$

$$K = \frac{L_m}{\sqrt{L_p L_s}} \quad (2)$$

$$Q = \frac{\omega L_{p,s}}{R_{p,s}} = \frac{2\pi f \cdot L_{p,s}}{R_{p,s}} \quad (3)$$

Inductive resonance, also known as resonant WPT, is a kind of inductive WPT whereby the electromagnetic system is made to function in a resonant state. The set of coils is coupled to components built up of reactive elements, like capacitors or extra coils, to satisfy this need. A resonant WPT system is shown in Figure 5 as a general design. These fundamental topologies contain a sole capacitor linked in series and/or parallel to the source and receiver [3, 5]. Unique resonant topologies are also the name given to such networks. An irregular interval topology with more complicated topologies is available. Nevertheless, multi-resonant topologies are what they are called. Resonant technology is used to power the vehicle's electricity wirelessly.

Advance power circuits and circuitry purifiers convert the received electricity to DC for the EVs' battery bank [10]. In comparison to the standard IPT, more combination networks in series and/or parallel topologies are included to both the source and receiver coils, not only does this configure the resonant design as shown in Eq. (1) but also to decrease extra damages, where f_r is the source and receiver coils' resonance frequency, and L and C are the emitter and recipient coils' self-inductance and resonant capacitor evaluations, accordingly. Once the resonance frequencies of the source and receiver coils are aligned, effective power transmission is achieved. The functioning frequency of the RIPT varies from tens of kilohertz to several hundred kilohertz. Without an electromagnetic core, the magnetic flux created at this frequency range has a considerable negative effect on mutual inductance, resulting in a drop in the coupling coefficient (k). Because the EVs' largest height varies from 0.15–0.30 m, the coupling coefficient in the RIPT ranges within 0.2 and 0.3. The coupling coefficient can be calculated using Eq. (2). The transmitter and receiver coils' self-inductance are L_p and L_s , respectively. The mutual inductance of the two coils is L_m . The mutual inductance value will be higher if the source and receiver coils are closely connected and vice versa.

Magnetic ferrite cores are used in numerous configurations in the wireless transformer design to increase the coupling coefficient. The next part will go through the specifics. Skin and proximity effects are powerful at high frequencies and impair power transmission efficiency. To circumvent such problems, individual isolated tiny, coiled coax cable Litz wire is typically utilized in the design. This facilitates helping to lower reactive power and raise the coil's quality factor (Q). The Q can be obtained from the previous equation (3). Eq. (3) determines the primary or secondary coil's frequency f and self-inductance L, and R is the coils' resistance.

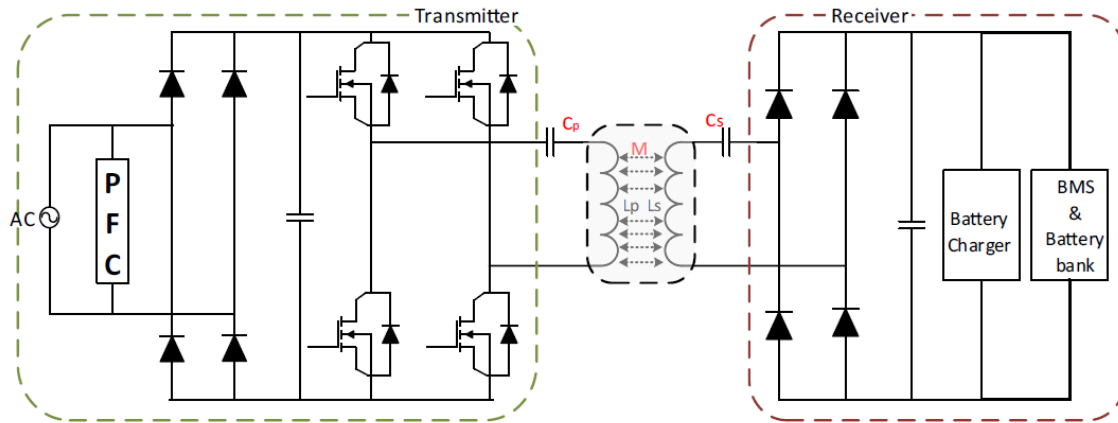

Figure 5 Resonant Inductive Power Transfer is shown as a schematic representation.

2.3. Combination Networks

Either the non-compensated and parallel-parallel systems are ineffective for any form of wireless charger that operates over a long gap and transmits a vast amount of power [12]. They attain optimum efficiency exactly when they provide a significant amount of power; on the contrary. As a result, they might be employed in limited microgrid battery chargers that don't need to be frequency-tuned. The series-series combination gives a reasonably significant amount of power despite a vast operating distance compared to the other two topologies. However, the efficiency peaks just when the resonant frequencies aren't operating. As an outcome, the system must be run at a balance between usable power and transmission efficiency.

Notwithstanding this, the technology is appropriate for a vast amount of power for charging an electric vehicle. Because series-parallel combination has more drawbacks than benefits, it shouldn't be advised for every battery charger. The series-series combination delivers the most exemplary demonstration across all investigated parameters, although it is much inferior in terms of power delivery. Nevertheless, for frequency spectrum adjusted microgrid battery chargers, it may be advised, the combination networks are depicted in Fig. 6.

Adjustments are required to eradicate phase mismatches within the current and the voltage and lessen resistance on the primary side. The use of a supplementary combination network improves wireless power transfer and efficiency. Furthermore, the WPT's network topologies are chosen based on the application's needs. The capacitor's value meagered from its dependency on magnetic coupling and quality factors. In an SP-based compensated WCS, mutual inductance has no effect on the value of the main capacitor combinations, and it may transmit more power than a classified system. It is, nevertheless, susceptible to load variation. The first advantage is that the capacitor value on the primary and receiver sides is self-sufficient from the load value and the mutual inductance factor. [10,11,12] As an outcome, the source and receiver sides' resonance frequencies are fixed by the primary and secondary coils' self-inductance rather than load value and the mutual inductance factor. The second advantage is that by towing active power at the resonant frequency, such systems preserve a single power factor since the feedbacked impedance from the secondary coil does not include an unreal component to the transmitter coil. Table 1 summarizes the extra benefits and features of the various combination networks used in the WPT for EVs.

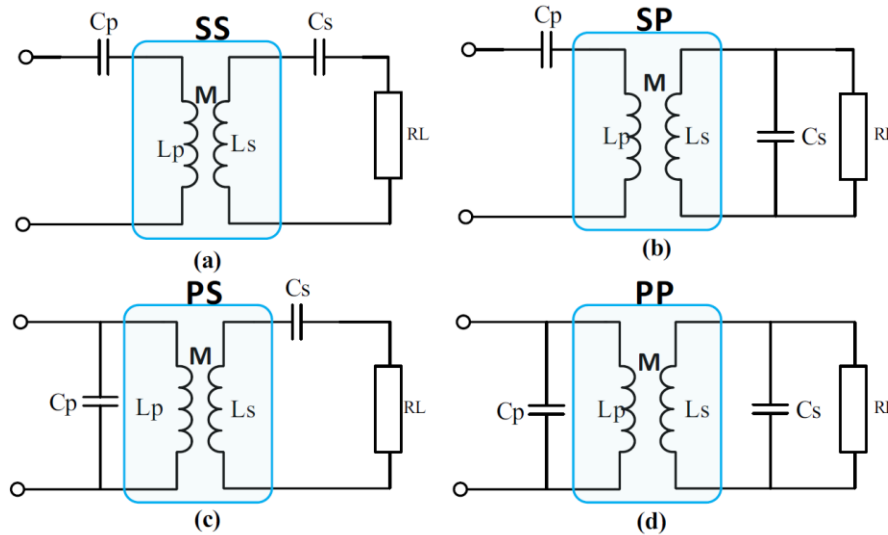

Figure 6 Combination topology (a) Series-Series (b) Series-Parallel (c) Parallel-Series (d) Parallel-Parallel.

Table 1 Combination networks' advantages and characteristics.

Features	Series-Series (SS)	Series-Parallel (SP)	Parallel-Series (PS)	Parallel-Parallel (PP)
Power transfer capability	High	High	High	Low
Sensitivity of power factor over distance	Less	Less	Moderate	Moderate
Alignment tolerance	High	High	High	Low
Impedance at resonant state	Low	Low	High	High
Frequency tolerance on efficiency	Low	High	Low	High
Suitable for EV application	High	High	Moderate	Moderate
Primary capacitor	$\frac{1}{\omega^2 L_p}$	$\frac{1}{\omega^2(L_p - \frac{M^2}{L_s})}$	$\frac{1}{\omega^2(L_p + \frac{\omega^2 M^4}{L_p R_{load}})}$	$\frac{1}{\omega^2 \left[\left(L_p - \frac{M^2}{L_s} \right) + \frac{\frac{M^4}{L_s^2} R_{load}^2}{\omega^2 \left(L_p - \frac{M^2}{L_s} \right)} \right]}$
Secondary	$\frac{1}{\omega^2 L_s}$	$\frac{1}{\omega^2 L_s}$	$\frac{1}{\omega^2 L_p}$	$\frac{1}{\omega^2 L_s}$
Load	$\frac{\omega L_s}{Q_s}$	$\omega L_s Q_s$	$\frac{\omega L_s}{Q_s}$	$\omega L_s Q_s$

2.4. Wireless Transformer Topologies

Wireless charging systems use many element layers in the transmitter and receiver pads to enhance power transfer efficiency and prevent electrical noise while staying cost-effective. The three aspects of the wireless transformer pads are the coil, insulating components (ferrite and aluminum sheet), and shielding and supporting sheets [13]. The wireless transformer pads are shown in a variety of angles in Fig. 7.

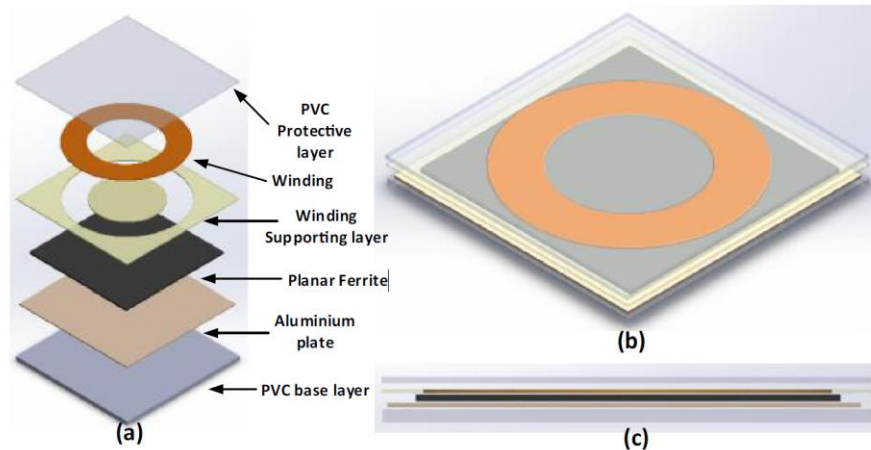

Figure 7 (a) schematic representation (b) overhead image (c) frontal view of a wireless transformer

2.4.1. Coil Properties

A wireless air-core inverter is used in WCS for EVs to transmit a small amount of power to a vast amount from the emitter to the recipient. Several flat coil forms, including round, rectangular, and mixed topologies, have been employed in the wireless transformer configuration to boost efficiency and solve mismatch difficulties within the source and recipient pads, as illustrated in Fig. 8. There are two types of wireless charging coils: polarized pads (PPs) and non-polarized pads (NPPs). The perpendicular (vertical) and parallel (horizontal) parts of the flux are generated by polarized pads, which are made up of several coils and configurations. Non-polarized pads, on the other hand, have a single-coil shape that exclusively creates perpendicular (vertical) flux parts. NPPs are traditional coil shapes, including round, square, rectangular, and hexagonal. The round coil is a familiar and often used configuration in wireless transmission because the eddy current is maintained to a minimal level in this design (No notches are present). The inner width may be changed to modify the magnetic flux arrangement. The electromagnetic field circuit would be round shaped for tinier center width, dramatically enhancing the coupling coefficient. The magnetic flux distribution zones may be enlarged with less amplitude compromise by expanding the center diameter to assist with misalignment concerns. When the counterbalance space within two coils exceeds approximately 40%, the recipient power decreases to zero. Because their ends are adequately aligned, square and rectangular coils are appropriate for installation assembly. However, sharp corner edges raise inductance by generating eddy current and increasing impedance and high-temperature surfaces. This precludes it from being used in high-power devices. In contrast with the round and square coils, rectangular coils have a higher horizontal misalignment tolerance. On the other hand, hexagonal coil geometries have the highest power transfer efficiency in the center of the emitter and recipient coils. However, there is a considerable loss in power if it exceeds the coil's end. Coils with an oval shape have a higher tolerance for misalignment, but they are not appropriate for high-power devices. PPs are made by assembling coils in several forms and various structures owing to their poor performance due to horizontal mismatch. These forms are appropriate for both single-phase and three-phase applications. PPs pads or couplers include the solenoidal coil, double D (DD), Double D quadrature (DDQ), bipolar (BP), and Quad D quadrature (QDQ). Solenoidal coils are made by winding coils around a flat ferrite surface, producing polarized sharp arching magnetic fluxes on each side of the coupler. This is accomplished by joining two coils magnetically in series and electronically in parallel. The fluxes of such polarized fluxes are higher than the fluxes of the NPP. Double D (DD) polarized pads contain two square or rectangular coils that create flux solely in a single path (against the ferrite plate) and have extremely low leakage fluxes at the margins. It has considerable merits because it may be used in both horizontal (X and Y) and vertical (Z) orientations. Furthermore, this design may give the discharged coil an outstanding coupling coefficient and quality characteristics. This pad may be utilized in both static and dynamic applications for primary coupling because of its better tolerance for horizontal misalignment. When equaled to the round pad, the Double D quadrature (DDQ) coil is an upgraded variant of the DD pad that produces twice the flux height. The Q coil manufacturing versatility and the benefits of the DD pad significantly improve misaligned longitudinal issues. The DDQ coupling is ideal for primary or secondary systems using single or three-phase power sources. Its capacity to capture both sine and cosine magnetic flux vectors makes it a tremendous supplementary pad. Bipolar (BP) charging pads are made up of several coils of equal size. In contrast with the DDQ pad, the BP pad needs an estimate of 25 percent to 30 percent less copper in its manufacturing. In applications that are either single-phase or three-phase, however, within both the primary and secondary coils, there is a 30° angle mismatch that reduces the coupling coefficient by 13%. Quad D quadrature (QDQ) pads have been proposed to massively increase functionality to address the receiver, particularly for mismatch and flux levels. For the purpose of configuring wireless transformers, such forms need two or more round and square coils. QDQ pads have a much wider coupling coefficient of 0.33 at 0.015 m long and can transfer enough power even with a 50% shift of misalignment. Fig. 9 shows multiple shapes with different structure for the ferrite in the design.

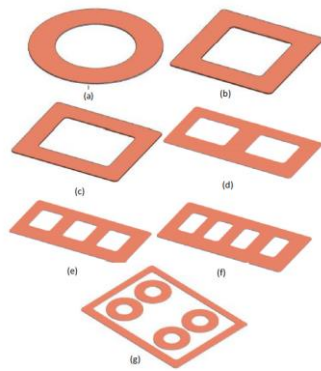

Figure 8 Coil appearance (a) Round (b) Square (c) Rectangular (d) Double D (e) Bi-polar (f) Double-D quadrature (g) Quad-D quadrature.

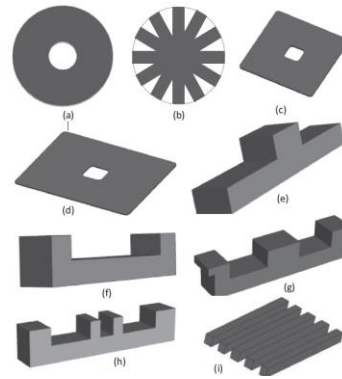

Figure 9 Ferrite appearance (a) Round (b) circular striated (c) square (d) rectangular (e) T-core (f) U-core (G) E-core (h) Double U (i) striated blocks.

2.4.2. Magnetic Ferrite Properties

Dynamic Wireless Power Transfer (DWPT) employs a high-frequency, powerful magnetic field to transmit electricity wirelessly. EMC is a significant issue because numerous delicate electrical circuits accompany the DPWT system [8,9,12]. The need for a shield to protect the frequency structure. Nevertheless, the configuration sets are among the criteria. Once the frequency is 100 kHz, the electricity concentration transmitted to the consumers is 200 mA/m², as per the International Commission on Non-Ionizing Radiation Protection (ICNIRP) standard. The parameters might have an impact on the nervous system in humans. The specific absorption rate (SAR) barrier is 2 W/kg. The power concentration limit is 10 W/m²; if the radiation to the human body exceeds these limitations, the body organs may be burned.

There are two types of outflow field repression: inward shielding and outward shielding. A magnetic way is established using an electromagnetic element or a field blocking mode using a vile magnetic to penetration metal plates in passive shielding. Utilizing magnetic elements increases self-inductance and mutual inductance. The magnetic flux arrangement is enhanced because of the enhanced coupling coefficient, and the transmission loss is reduced. The shielding effect, on the other hand, is just temporary. A metallic shield is often employed in a high-frequency magnetic field to decrease electromagnetic noise. Basic structure and ease of usage are two benefits.

On the other hand, metallic shielding is not able to entirely protect the transmitter and receiver. Impedance and eddy current are present on the uncovered circuit, increasing the temperature difference. A unique active shielding approach was suggested. Numerous metallic layers are inserted in a traditional ferrite plate. The magnetic noise is successfully decreased, according to the findings of the experiments. In case of including a power source, extra coils are installed at the WPT system to provide a canceling field for active shielding. The amount of area needed is less as against metallic shielding. A switching arrangement is carried out to regulate the crowded field's peak and phase angle by changing the number of adjusted capacitors. The sustainable mass conveyance was used in a study. The shielding coils are positioned on the coupling technical side. After that, the current caused by the loss field is measured. For field blockage, a magnetic field with the equivalent amount but reverse sign as the loss is generated.

2.4.3. Configuration in both Protection and System Enhancing

The transmitter pad in WEVCS is situated beneath the road's concrete structure and is capable of handling a vehicle's weight as well as additional vibration. The overhead and base layers of the charging pads are composed of PVC plastic sheets to provide structural stability. The length and width of the charging pad are determined by its scale and thickness and range from 0.005 to 0.020 m. Clear acrylics are sometimes put around the coil to endorse and improve the charging pad's aesthetics.

2.5. Health and Welfare Challenges

Irrespective of the advantages of the wireless power transfer and its benefits that facilitate electric charging systems for electric vehicles, there have to be safety precautions and procedures to ensure that there is no question at all about the perceived safety of electric vehicle charging process since uncontrolled micro active waves may harm physical tissue along with electronic systems. [14,15] The network should be constructed in such a way that humans are only subjected to the electromagnetic field (EMF) to the extent necessary. As a result, it is critical to guarantee that people, as well as different electronic devices in the vicinity, are not exposed to intense microwave light when wireless power is sent to designated transmitters. In reality, several

bodies have created a number of laws for electromagnetic fields in order to ensure human welfare and electromagnetic sufficiency.

Although interaction with the electromagnetic field is inevitable, the amplitude of EMF is kept considerably less than the permissible limit. To increase safety, a split power source for on-line electric vehicles, as well as specifically constructed coils, would further minimize EMF levels. Over and above, various continuing studies and innovative models have been modeled and checked to improve the WEVCS to be a straightforward process and handy for consumers. A high-power device is always a fire hazard threat due to flaws or problems in engineering elements. This may endanger human safety in either houses or power stations. Cable insulation collapse or switch device breakdown may result in electrical hazards, thus leading to fires and destruction. Regulations, guidelines, and manufacturing standards have to occur to prevent such technical problems. Considering the meteorological conditions, temperatures in certain countries may range from bitterly cold to scorching hot across the year. In general, the WEVCS enforces health and safety requirements over the design, improvement, manufacturing, and installation (including service) stages to guarantee the consumer's welfare.

2.6. Health and Welfare Regulations

Safety research may be valuable in finding the rated power that leads to radiation exceeding the restrictions via experimentation. A metric to be even more concerned about is overtones. The allowed transmission power was reduced by over 40% in the existence of overtones. The estimate of ambiguity is a striking absence from most of the research. Outdoors measures, where so many unpredictable variables could emerge, are more crucial than experimental data [14,15,16,17]. Overall, ambiguity analyses may be included in a radiation limitations conformance analysis. The rationale for this is because, overall, the risk is magnitudes below the limitation, reducing the requirement for an ambiguity allowance in aspect. The widespread consensus is that existing radiation safety levels are appropriate in most cases.

Nevertheless, additional research is needed to approach the mechanics of body contact with electromagnetic fields. The expected more excellent knowledge does not always indicate a shift in present norms. SAR estimates using specters ought to be done with caution since height significantly impacts absorption via human body resonances. The phantom forms might be unique. This might be in line with a regulation issued by the European Commission as part of Horizon 2020. Because the WPT is still in its infancy, it appears that established methodologies for assessing WPT are essential. In any event, given the possibility of kW functioning in close proximity to people, radiation danger safety should be included in the technical configuration process for improved outcomes. Numerous situations have been established in the review papers that WPT systems do not break the radiation restrictions when people are placed at a distance of a few centimeters from the battery charger. Domestically, an electromagnetic field that surpassed the optimum peak value was discovered.

In contrast to radiation protection investigations for frequencies up to 10 MHz, that should be mentioned. [18] As stated in Table 2, SAE International has announced TIR J2954 wireless power transfer regulations for PHEVs and EVs with a typical functioning frequency range of 81.39 to 90 kHz for illumination and passenger vehicles. In addition, for the experimental and shown objective of the WEVCS, these regulations cover power levels, electromagnetic restrictions, and the least efficiency. The SAE J2954 WPT committee performed a number of benches (standardization testing) and vehicle validation tests (complete vehicle tests). Additional regulations for alignment techniques, dynamic WEVCS, and wireless bi-directional power transmission will be announced in the future.

Table 2 PHEV/EV Wireless Charging SAE Internal Regulations (J2954).

Properties	Wireless Power Transfer Sections			
	Level 1	Level 2	Level 3	Level 4
Peak Power Input (kW)	3.7	7.7	11	22
Least Efficiency Meet (%)	<85% Misaligned			
Functioning Frequency (kHz)	85			

2.7. WEVCS Implementation Challenges and Roadblocks

An inductive coupling wireless power transfer system's (ICWPTS) purpose is to transmit electricity through a distant magnetic connection to a moving device. [19] Its scientific advancement is based on a combination of magnetic and power signals as a single platform. Developing a magnetic coupling form with a tiny distance would lead to a high magnetic coupling coefficient and higher power transfer capabilities in the form of magnetic structures. Modeling and depicting the electromagnet device, as well as associating its physical properties, including its electrical response, is critical in order to: (1) anticipate circuit function and (2) give the understanding required to produce an optimal configuration. In addition, an ICWPTS' magnetic configuration incorporates the magnetic characteristics of an electrical transformer as well as an inductor. Hypothetical advancements in magnetic properties, mutual inductance, leakage inductance, and their relationship to structural properties and AC wastage, which are crucial in electrical power systems that are still possible. Multi-stranded braided Litz wiring is often utilized in ICWPTS to lessen the contact and similar effects associated with the coils. The construction of an

effective ICWPTS necessitates the modeling and advancement of operational analysis of this kind of factor linked with Litz wiring.

On the contrary, electromagnetic circuit encompasses a wide range of topics such as devices, automation, and telecommunications. The key issues become the investigation and modeling of switch-mode non-linear devices. ICWPTS, like many electromagnetic power devices, rely heavily on fundamental breakthroughs in switch-mode non-linear concepts for ongoing growth. Furthermore, an ICWPTS power supply's weak magnetic coupling between the primary and secondary coils makes it harder to evaluate than a standard strongly coupled transformer. This raises the device's complexity, necessitating suitable adjustment and management considerations in the configuration.

Limitations in terms of technology

In contrast to a standard cohesively linked configuration, constructing an ICWPTS imposes many unexpected limitations due to the distance. The magnetic circuit's comparatively long length leads to less mutual inductance and significant leakage inductances. Eddy currents may occur in the electromagnet device near the object as a result of surrounding flux, causing power wastage and EMI. Resulting in higher friction wastage, leakage inductance, and coil capacitance, functioning at upper-frequency range poses particular configuration challenges. This is an outcome of the leakage inductance, and coil capacitance spread across the coils in the magnetic device, determined by the coils' geometrical alignment and distance. Skilled SMPS (switch-mode power supply) developers understand that perhaps the outcome of an SMPS is determined mainly by the magnetic elements' configuration and execution. Rising power wastage, elevated peaks requiring snubbers or brakes, inadequate bridge legislation across several outcomes, interference as to intake or outtake, limited switching frequency spectrum, and other issues are all caused by fundamental factor features in high-frequency inductive power transfer systems. The following are some important considerations and implementation constraints:

Addressing the power requirements. Due to restricted capacity on the receiver side and precise power flow constraints, delivering the needed power to a load through ICWPTS might be challenging.

Switching velocity. The capacity of an ICWPTS may be reduced by functioning at a higher frequency. One of the significant limits is the switching velocity. Isolated gateway transistors (IGBTs) featuring consumer applications up to 3kV/2kA output and a switching frequency of 80 kHz appear to be the best system for ICWPTS. MOSFETs (Powered silicon ferrite magnetic coil transistors) can switch at MHz rates, yet their electrical parameters are too weak for high-power ICWPTS.

Function Efficiency. Obtaining high network power efficiency is difficult because of several metallic and ferrite inefficiencies. Temperature increases to its peak. This is a critical aspect in keeping a system working within a suitable temperature value, mainly when the device is employed in a temperature-controlled atmosphere.

Physical Properties. In constructing an ICWPT system, dimensions and load are restricting concerns. In electrical machinery, the transformation necessitates the utilization of inductors, which are often the circuit's most significant and heaviest part. The configuration of such features influences the total device dimensions, power transmission efficiency, and price.

Management and Reliability of the System. Maintaining a solid system across a diverse variety of load and magnetic coupling fluctuations is critical in practical uses. If not constructed appropriately, alteration regulated ICWPT power supply might become chaotic.

Efficiency in terms of price. Because of the sophisticated power digital circuits and magnetoelectric architecture, modern ICWPTS are more expensive than conventional cabled versions. Improving the framework to cut the price for practical uses is a difficult challenge.

Accountability. ICWPTS's actual functional products must meet system reliability (EMC) and safety requirements, which may be a problematic configuration process. The issues listed may indeed interfere with one another, rendering system optimization extremely challenging. According to actual limits as well as objectives, barter is frequently required.

3- MATLAB/SIMULINK Simulation

A DC voltage source with high frequency boosts the passive element and makes it easier to use to transfer power wirelessly through the capacitance to the transformers [4,11]. The DC signal will cross the h-bridge (as an inverter) with a pulse generator shifting 50%. A frequency of 50 kHz to convert the system into AC to be able to interact with the capacitance/Inductance transformers then electromagnetic wave will occur, transferring the power to the receiver side to go through the h-bridge (as a rectifier) again to convert the signal back to DC from AC to charge the battery bank as a DC charger.

In this simulation, assuming the existence of a grid and a power factor correction, and a rectifier, the author will start with a DC power supply; the value of the capacitors will be calculated to give maximum power through the resonance equation.

3.1. Static Wireless Charging System

Fig. 10. Shows that the capacitors are used with the coils to eliminate the eddy current and the reactive power. Thus, will result in having the maximum power transferred throughout the capacitive wireless power transfer; this to be said in another way is to get rid of the inductor's effect by installing capacitors instead, resulting in an increase of the value of the quality

factor as well as making the current and the voltage in phase with each other as shown in Fig.11, 12, given the values of R=10ohm, C=1000 mf, L=1 mH, V=600 V.

$$\omega = \frac{1}{\sqrt{LC}} \quad (1)$$

$$\omega = 2\pi f \quad (2)$$

From eq. 1&2

$$\omega = 2\pi * 50000$$

$$\text{Then, } 2\pi * 50000 = \frac{1}{\sqrt{1*10^{-3}C}} \rightarrow C = 1.0132 * 10^{-8}$$

With this value, the resonance is achieved, and the maximum power is transferred with maximum efficiency and a unity power factor.

Note that the author inserted a gain of 50 to the input current to make it clear in connection with the Voltage to appear in phase to each other.

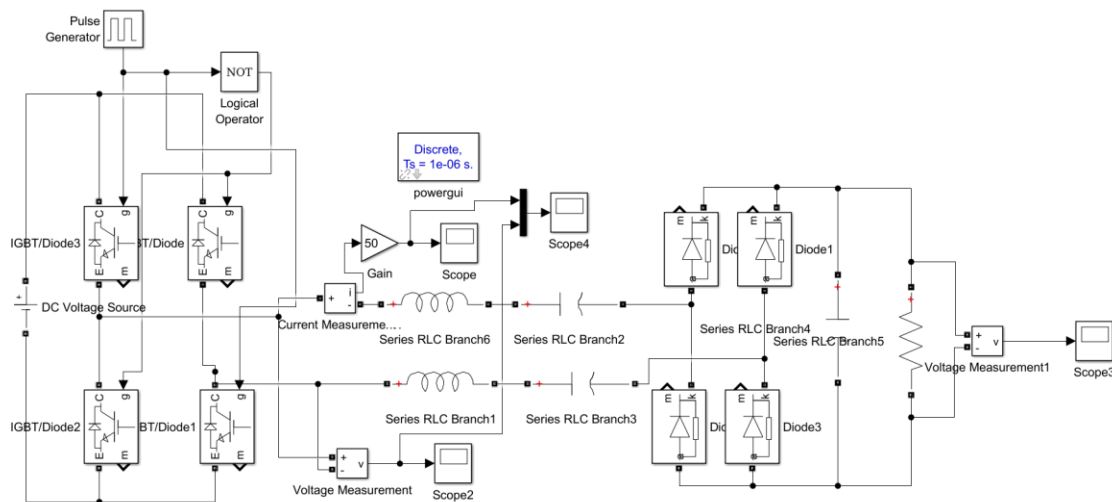

Figure 10 Static Wireless Charging Simulated System

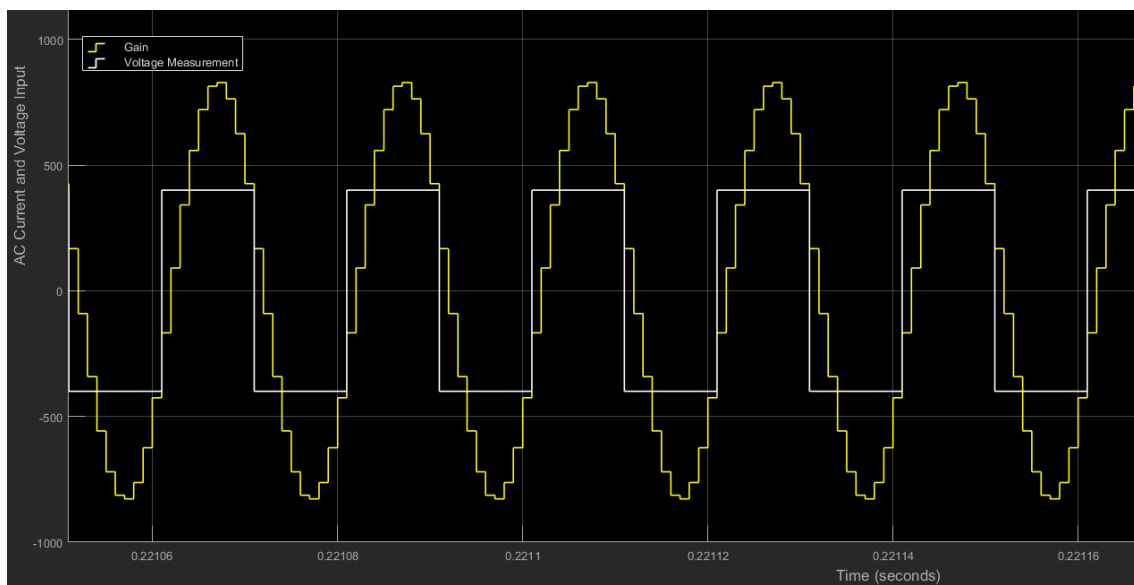

Figure 11 The AC Current and Voltage Input

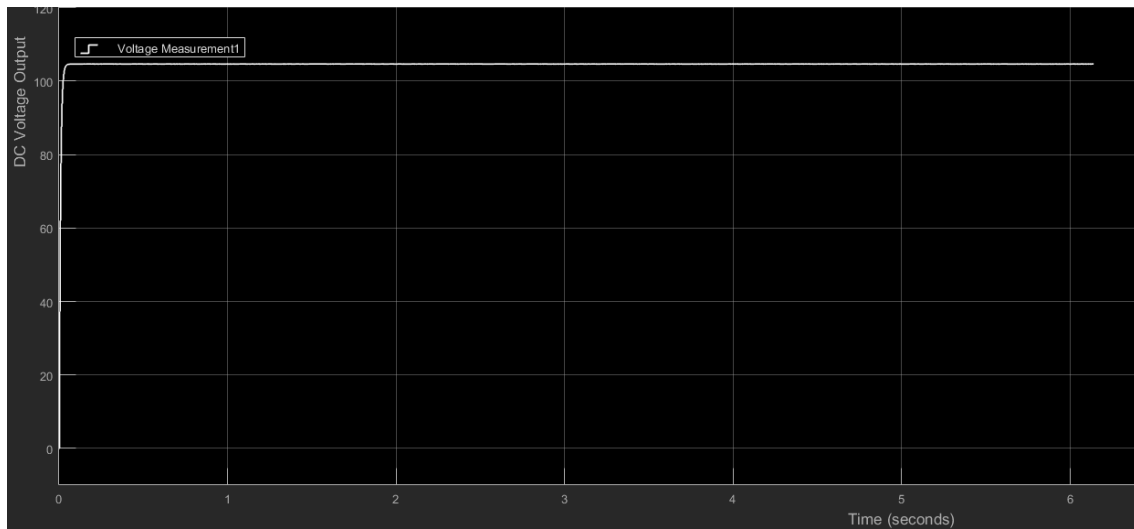

Figure 12 DC Voltage Output

3.2. Dynamic Wireless Charging System

The author will apply the resonance technique to make the efficiency 100% as shown in Fig. 13, and by doing so, the power will be transferred entirely without any reactive power. The quality factor will be one, applying capacitors in series with the transformers to cancel the reactive effect of the inductors as shown in Fig. 14,15. as the input and the output. Note that the current value is multiplied by 50 to see the figures as the current value is minimal.

$L=1\text{ mH}$, $M=0.1$, $V=400\text{ V}$.

$$\omega = \frac{1}{\sqrt{LC}} \quad (1)$$

$$\omega = 2\pi f \quad (2)$$

From eq. 1&2

$$\omega = 2\pi * 50000$$

$$\text{Then, } 2\pi * 50000 = \frac{1}{\sqrt{1*10^{-3}C}} \rightarrow C = 1.0132 * 10^{-8}$$

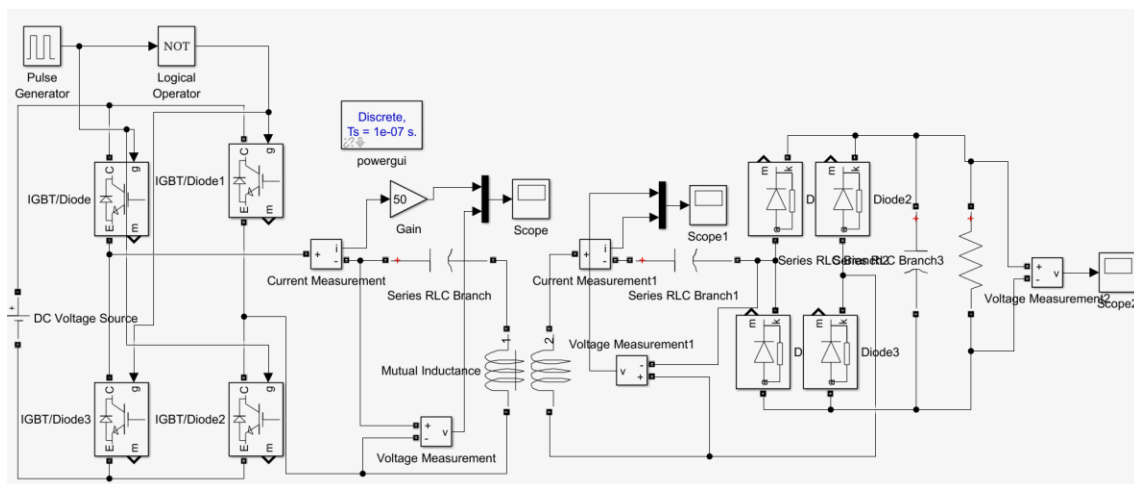

Figure 13 Dynamic Wireless Charging Simulated System

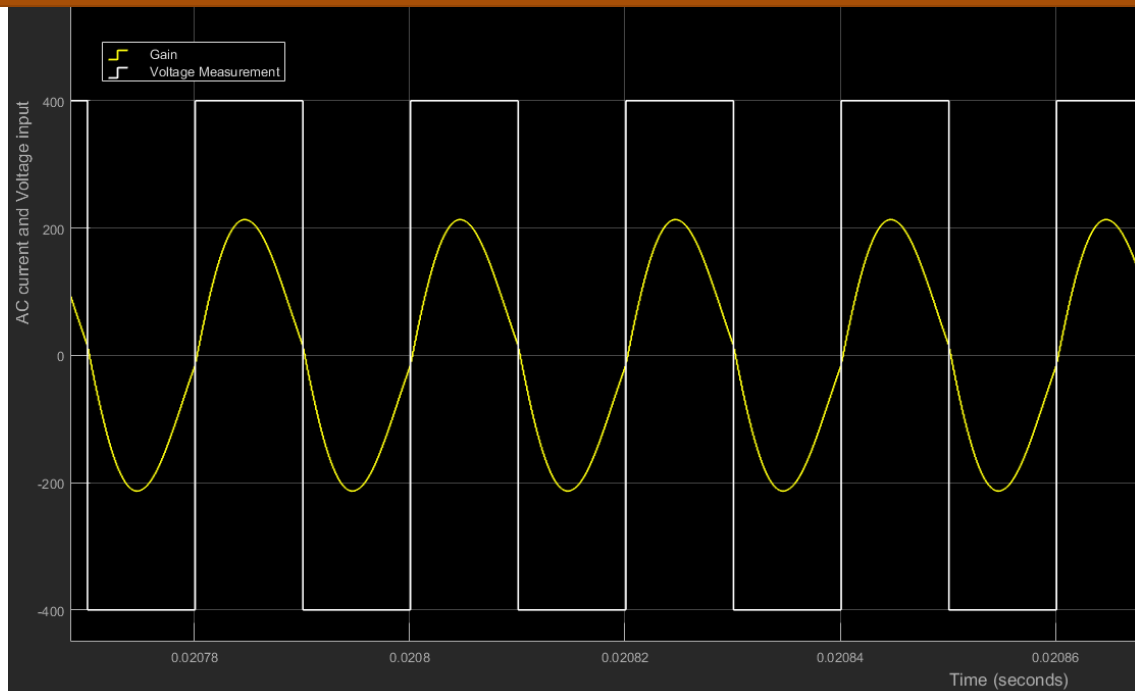

Figure 14 The AC Current and Voltage Input

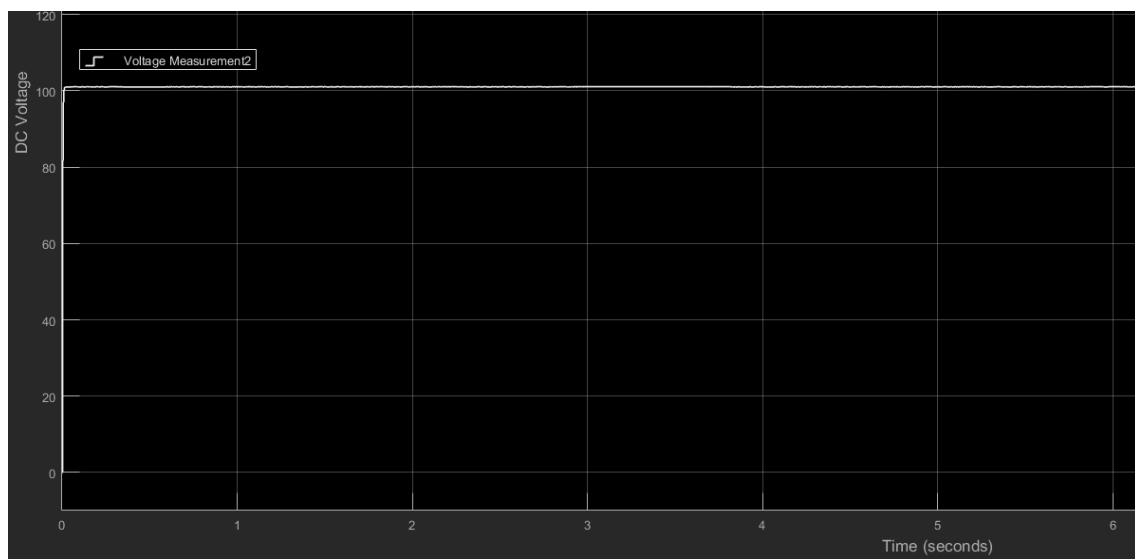

Figure 15 DC Voltage Output

The Finding

The power has wirelessly transferred completely in the static and the dynamic condition. Showing the voltage as a straight line and stable after the power transmission which means it's confirmed that the static and the dynamic wireless power transfer is a success, and it can be used in so many applications in the future if applied correctly as the following section will show and discuss.

Also, the results shows that the power was transferred without any loss or leakage and with a unity quality factor and 100% efficiency. And the voltage and the current are in phase with each other's.

4- Applications of WEVCS

Wireless chargers' adaptability expands the range of conditions in which electric vehicles may be charged, including not just while static but also when briefly halted or even when moving. Consequently, the battery's price and mass may both be

decreased since the battery bank can be lessened. There are three types of wireless charging modes: static, stationary, and dynamic [3]. Figures 16&17 depict these types of performance.

4.1. Static Wireless Power Transfer

Static WPT happens when the charge is carried out at a defined location, and the vehicle is supposed to be switched off because the charge is carried out. Now that's the situation with domestic chargers and garage chargers. Complicated functionalities may be included in the chargers, such as a high proportion suggesting which vehicles should be parked to avoid winding alignment. In Germany, Bombardier has designed a magnetic-resonance charger for vehicles that produce 200 kW in a stationary form.

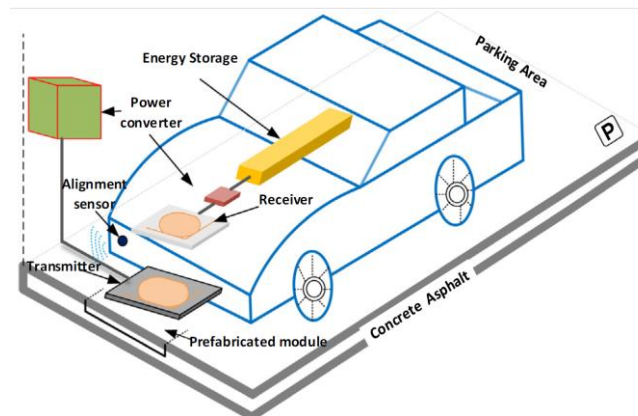

Figure 16 Static wireless electric vehicle charging system schematic.

4.2 Quasi-Dynamic or Stationary WPT Charging System

The quasi-dynamic or stationary WPT charge is another form of WPT charge. The following two peculiarities characterize this sort of charge. To begin with, the vehicle is stopped, yet the motor continues to operate. Moreover, this scenario persists for just a brief time, insufficient to fully charge the battery. This form of charge is ideal for providing power to public transportation vehicles when they stop at bus/tram stations or taxi stands. This was the situation with road 63; a bus was put to the test in Mannheim, Germany, in 2013. The bus was capable of charging its batteries while loading travelers, allowing it to continue operating uninterrupted. This procedure was made possible by modifying the bus route. Additionally, personal vehicles might be charged during traffic signals or in traditional traffic conditions.

4.3. Dynamic Wireless Power Transfer

The dynamic method means to charge the vehicle while it is moving. That is, while it usually is moving on the main route. This is indeed a primary operating method in WPT for EVs. Particular components of specific routes might be outfitted with devices to allow WPT for personal vehicles as well as public transportation vehicles like buses, trains, and trams. This sort of charging encourages the use of electric vehicles that are powered by the road wirelessly using electromagnetic power transferred by a series of primary coupling installed inside the road to the secondary coupling in the vehicle. The Victoria initiative has previously tried dynamic charging in a few places in South Korea and Spain. Conductrix Wampler in Turin (Italy) has developed a model that uses wireless power transfer to charge a bus whenever it stops and at the conclusion of a bus line.

Multiple groups are already using wireless technology to charge electric vehicles. Some illustrative instances are given. The research on the widespread deployment of pure electric vehicles in modern transportation networks was carried out. This widespread adoption necessitates the development of stable EV technology and innovative charging methods that give a user experience comparable to that of today's vehicles. Electric vehicles may be able to gather power from the roadway in a capacitive or wireless way in the future (dynamic charge). It shows the necessity for a smaller battery. Better on-line recharging options will increase the driving experience and battery longevity of EVs, sole as the overall power efficiency and pricing, in comparison of existing models of a more significant fixed battery bank using quick charging or smaller batteries. The disconnected initiative is yet another instance. This project looked at how wireless charging of electric vehicles in metropolitan areas might increase vehicle transport efficiency and long-term viability. It looked at how sophisticated wireless charging configuration may helpfully integrate electric vehicles into roadways while also increasing consumer acceptability and overall functionality. The technological viability, practical difficulties, compatibility, usage experience, and cultural effects of wireless charging were all thoroughly examined by disconnected.

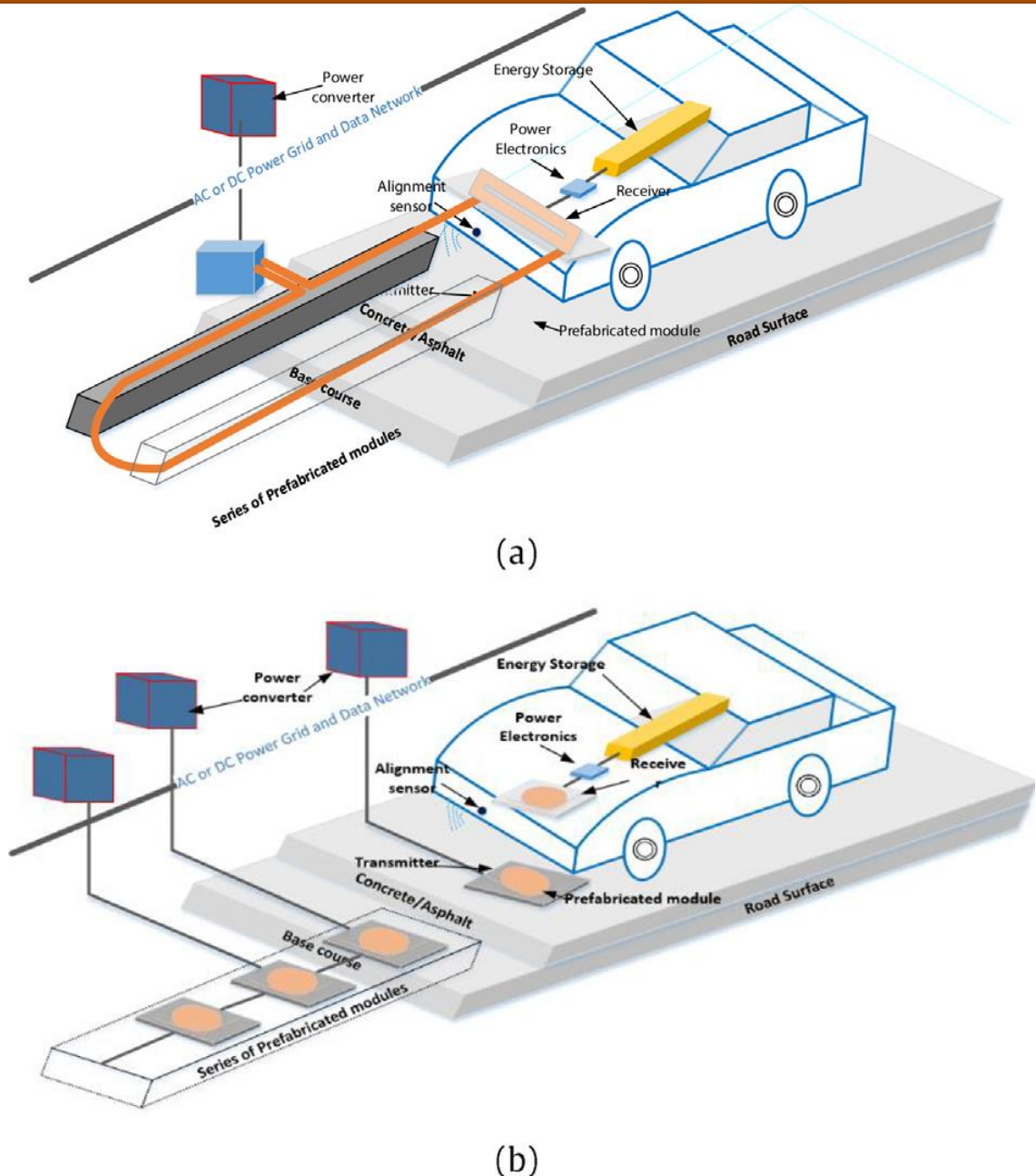

Figure 17 This graphic depicts a dynamic wireless electric vehicle charging system.

5- WEVCS Promising Applications

5.1. Vehicle to grid wireless communication (W-V2G)

The advantages of adopting electric vehicles are not limited to environmentalism; the innovation will also be part of smart devices. EVs may be thought of as movable producers with almost little friction in this regard. EVs might potentially offer power to the electric system with a quick reaction period if needed. Its capability makes it easier to control electrical networks, especially in areas where renewable energy sources are widely used. Whenever the network detects a surplus of renewable energy production, it might be used to recharge the vehicle battery bank [3,5].

Similarly, the batteries might provide supplementary control for voltage and frequency, for example. As a result, an EV's battery bank might serve two purposes: Getting energized or working as a generator are two different things. V2G activities are what they're called. The appropriateness of V2G procedures is determined by a number of parameters, including network condition and charging system. Sophisticated methods consider such factors and offer suggestions for how and where the charge/discharge procedures should be carried out. The power of V2G reached 2.6 GW in 2017, and per the research firm

Navigates. Approximately one percent of a total of the worldwide network operations industry is estimated to be covered through this estimation.

Nevertheless, by 2026, this amount will be increased to 20.5 GW (4 percent of network operations). WPT system enables the implementation of an automated EV charge/discharge system. This feature is particularly useful for V2G procedures since it allows the charge/discharge procedure to be initiated while the customer can't fully be involved. Table 3 shows the difference between V2G charging systems and Fig. 18. shows the types of V2G power transmission. Since such activities ought to be extended forward, wireless chargers that can handle simultaneous load demand should be conceived and put in place: according to the network to the battery bank, and the other way around in compared to single-directional wireless chargers, bi-directional wireless power transfer (BWPT) need more complicated switching devices.

Table 3 Wireless V2G vs Plug-in V2G analysis.

Properties		Wireless V2G		Plug-in V2G	
Method		Wireless	Power	Classical	Conductive
Functioning	Frequency	81.9-90 kHz		16-100 kHz	
Power	Transfer	>90%		>90%	
Efficiency		Medium to High		N/A	
Distant Response		Medium to High		N/A	
setup Response		Automatic		Manual	
Operating Function		Automatic		Manual	
Power Transfer		Automatic		Manual	
Scheduling		Automatic		Manual	
Health and Welfare	Isolation	Wireless Transformer		Mandatory on-board transformer	
	Electric Shock	Low to medium		Medium to high	
	Hazard	Medium to High		Low	
EMI		High		High	
		High		High	
Power Transfer	Capability	High		High	
Convenience	Connection	Very High		Medium	
Compatibility	Connection	No Plugs		Variety of regulations (shapes and sizes)	

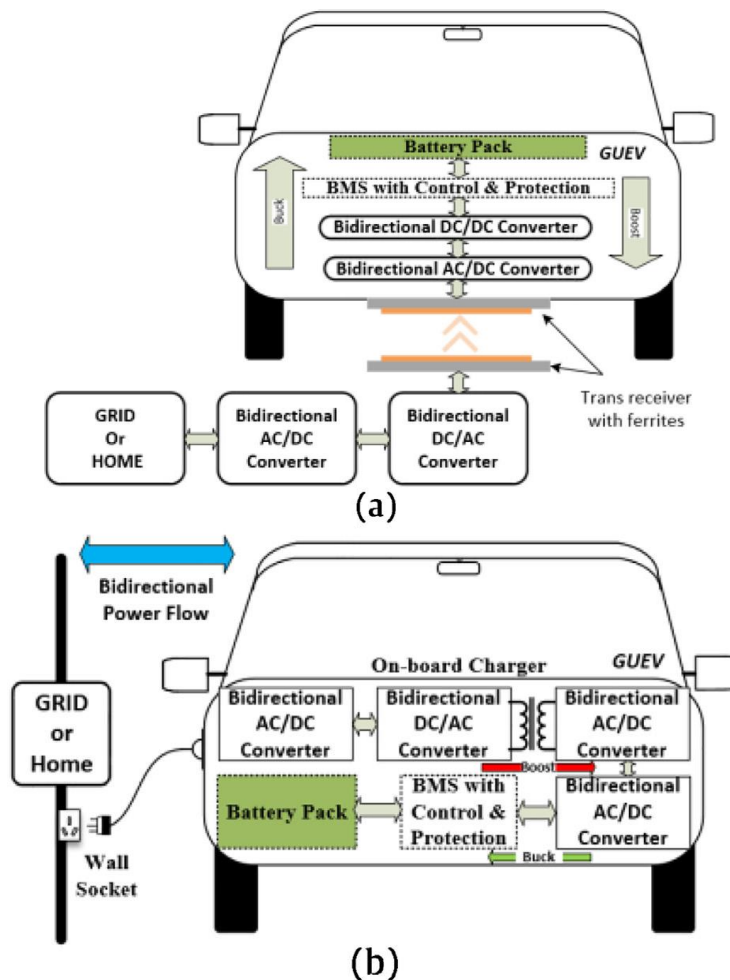

Figure 18 Applications using bidirectional power transmission(a) wireless V2G (b) plug-In V2G

5.2. In Wheel WCS

5.2.1. IW-WCS Configuration

The University of Auckland, The Korea Advanced Institute of Science and Technology (KAIST) [20], The University of Tokyo, Oak Ridge National Laboratory (ORNL) [21], and several other worldwide universities have all published research on DWPT in past years. System analysis, management hypothesis, inverter systems, resonant frequencies optimizations, and electromagnetic shielding techniques for DWPT are among the subjects explored. The world's most giant 1st WPT bus with 30 kW energy was designed by the University of Auckland and ConductixWampfler. A prototype with a 100 kW WPT capacity and a 400 meters route was also configured to continuously charge the model as it has no internal battery bank. Electric vehicles have been built at KAIST using operational electric vehicle technology. The vehicles are used for transport services in Gumi, and they operate on two different lines that span 24 kilometers. On such lines, the system can deliver 100 kW of electricity, including an efficiency of 85 percent. ORNL's dynamic charging system comes with a complete bidirectional converter that powers two transformers in parallel via a series circuit. The testing findings reveal that the electric vehicle's placement has a considerable impact on the performance and efficiency transmitted. To attain optimal efficiency, scientists of Tokyo recommended combining a feedforward regulator with a compensator to modify the switching frequency of the inverters in the DWPT system. A wireless in-wheel actuator is constructed using the sophisticated method based, as illustrated in Figures 19 & 20. The modern WPT runs from the vehicle's chassis to the in-wheel engine. A dynamic charging mechanism will allow the wireless in-wheel machine to be charged straight from the road in the coming years. The Korea Railroad Corporation (KRRRI), on the contrary, devised a WPT system for use on railway lines. A 1 MW, 128 m long train line was constructed to showcase the dynamic charging technique for electric vehicles.

The coupling system comprises a lengthy transmitter line and two tiny U-shaped metallic ferrites to boost coupling power. As power runs via a long transmitter line, it has a large inductance, resulting in a significant power loss. The compensating capacitors are positioned aligning lines to alleviate the overvoltage. Experts from the Japan Railway Technical Research Institute

presented a new coupling technique concept for electric transmission. The system can transmit 50 kW of electricity through a 7.5micrometers distance at a frequency of 10 kHz. Bombardier Primove of Germany is presently the market leader in WPT systems for electric vehicles and energy transfer. The research was principally carried out in order to improve the technology's utilization. However, the technical specifications of Bombardier Primove's WPT system have not been made public.

Since 2013, to provide high dependability while charging electric vehicles. The primary DC bus is powered by a parallel connection of k number of AC/DC power stations. This setting is used to improve the system's resilience. In case of a failure of a single AC/DC substation, that unit will be separated from the system, allowing the remaining power stations to remain operating correctly, preventing a power outage or reactive power. Numerous high DC/AC converters run in tandem to power each emitter ensemble. The power source on the AC system will not be stopped if a converter fails, as it would on the DC Power system. The engine has a DC system on the recipient side. Several transmitters provide AC/DC power correction factors to the DC systems at the same time. Via a regulator, the DC circuit operates the actuator; in the event that one of the power correction factors fails, the other transmitters may still power the DC circuit. Dynamic charging was accomplished by the Harbin Institute of Technology employing differentiated emitters in a parallel connection to the converter. Two plates of flat metal coiled along the same axis are placed on one another on the recipient side to eliminate the spots in which the transmitted power is null, enhancing the total efficiency. The mutual coupling is negated when the coil's two plates' location and size are designed using the decoupling concept, and excellent efficiency is attained at any placement. Despite the fact that numerous international research has been done with remarkable findings, elements like power transmission efficiency, configuration price, and service fees still need to be improved. High power lines, vital management techniques, and EMC are all significant issues for realistic DWPT deployment.

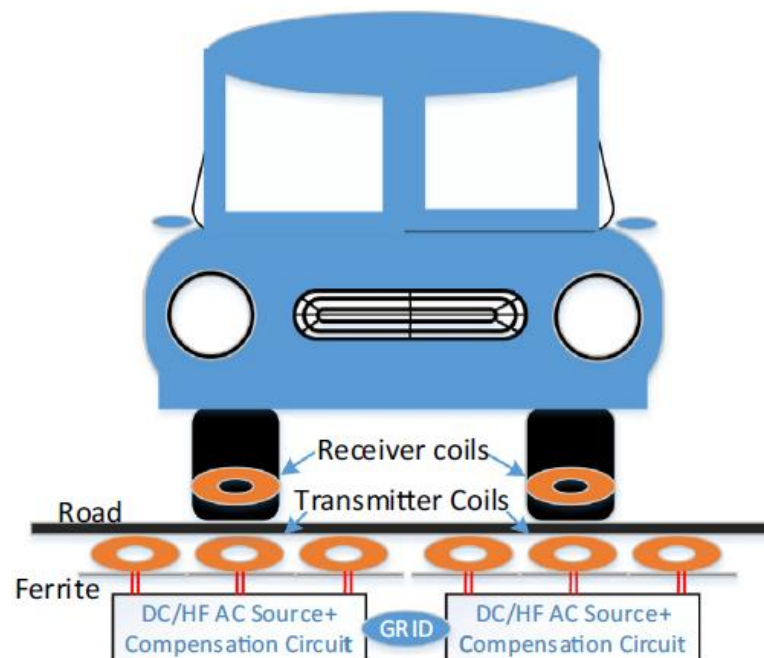

Figure 19 Static and Dynamic In-Wheel WCS Conceptual Illustration

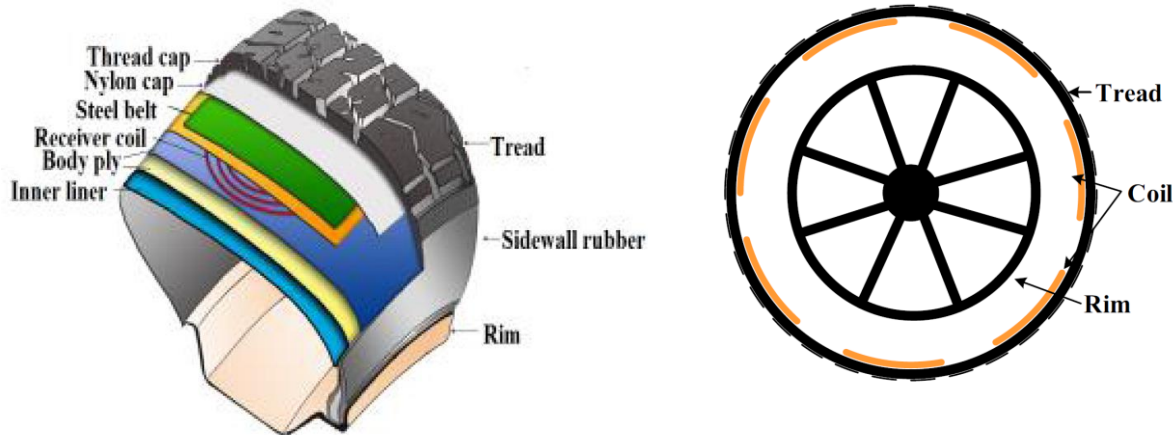

Figure 20 Internal coil positioning (a) and coil configuration (b) in the In-Wheel WCS.

5.2.2. Networked Review

A FEM simulation of an asymmetric prototype of a 0.01 m width metallic plate rubber tyre with 0.007 m air-gap and 0.017 m air-gap with source and recipient couplings was used to examine electromagnetic field spread and leakage. Fluxes in the static or dynamic IW-WCS. The magnetic flux concentration and the current concentration of the source coils with flat plate cores were created at 100 kHz. The tyre’s magnetic permeability was chosen (In the magnetic field, the rubber tyre has the exact penetrability as space). Due to the conductive substance, the inbuilt metallic plates draw few magnetic fluxes in their direction. As a result, the magnetic leakage fluxes in the wireless transformer are somewhat increased. Mutual inductance drops within two coils for a 0.01 m width tyre with a 0.007 m length, lowering the coupling coefficient (k) from 0.52 to 0.46. A simulation was done utilizing aluminum rim material situated roughly 0.04 m from the recipient coil within the tyre to better realize the rim’s influence. The short circuit inductance (Ls) is lessened from 45 to 35 microhertz, indicating that the aluminum rim is able to minimize leakage fluxes and alter coupling. In general, it aids in the reduction of the risk of health and welfare hazards in WEVCS design.

5.2.3. the contrast of In-Wheel vs Via-Wheel WCS

The IW-WCS and the existing via-wheel WCS for EVs are compared in Table 4. Previously explored via-wheel WCS employed a CWPT approach, whereas IW-WCS use a series-series resonant inductive-based power transfer mechanism. In comparison to IW-WCS, the coupling efficiency of the CWPT is considerably lowered with a bit of growth in space within the emitter and recipient coils. The IW-WCS also runs at 100 kHz and may be readily adjusted to current J2954 SAE regular frequency variations (81.39–90 kHz) by altering the amount of a series capacitor, but the CWPT operates at 50–55 MHz (that adheres to the radio frequency spectrum). Power transmission restrictions apply to this region because dangerous electromagnetic fields endanger human health and welfare. In addition, IW-WCS works with current wireless charging facilities, but CWPT necessitates the need for an advanced emitter topology on the base, which raises configurational expenses. In general, IW-WCS has the possibility to be higher in terms of efficiency than via-wheel WCS and can be readily enhanced for high-power devices.

Table 4 Qualitative Comparison of WCS In-Wheel and Via-Wheel

Features	In-Wheel WCS			Via-Wheel WCS
Method	Inductive	Power	Transfer	Capacitive Power Transfer
Wireless Transformer	Coils with Resonance			Copper Foil or Steel Belt
Coupling Efficiency	High			Medium to High
Air-Gap Dependency	Low to Medium			High
setup Dependency	Horizontal			Vertical
Functioning Frequency	100 kHz			50-55 MHz
Total Power Transfer	100 W			60 W
Power Transfer Efficiency	>80%			70-78%
Health And welfare Issues	Power	Capable of High-Power Transfer		Limited due to Tyre Safety
		Easy to Meet the Standards		Not Suitable due to RF range
Compatibility	Compatibility with Existing WCS			Required to Install a New Infrastructure

6- Conclusion

With current explored technology, this study provides a fundamental description of the WEVCS for fixed and dynamic applications, including a carried-out simulation. There have also been examples of a range of core and ferrite forms, which have been used in the design of modern wireless charging pads. Health and safety concerns have been raised, and current worldwide standards advancements have been presented to WEVCS. Recent studies and progression from a number of public and private organizations have been used to study and analyze state-of-the-art stationery and dynamic WEVCS. Finally, the use of Finite Elements Method (FEM) is used to research and simulate prospective future technologies. This article provides a summary of the most recent developments in the field of WEVCS in general. Its applications and possibilities are vast. Much focus on EVs currently is one developing efficient family-sized vehicles. However, a vast potential exists in the development of WEVCS, which can power EVs in cities that are really struggling with overcrowding and the transportation of their citizens in mass passenger vehicles that rely on fossil fuels.

7- References

- [1] Chun T. Rim, ChrisMi. Wireless Power Transfer for Electric Vehicles and Mobile Devices. Aptara Inc., Ind. 2017, p. 5.
- [2] Johnson I. Agbinya. Wireless Power Transfer. Melbourne Institute of Technology, Aus, 2016. Vol 45, p. 386.
- [3] Alicia Triviño-Cabrera, José M. González-González, José A. Aguado. Wireless Power Transfer for Electric Vehicles: Foundations and Design Approach. Springer. Power System. May 2019.
- [4] Kumar, K. H., Srinivas, V. Y. S., & Moulali, S. Design of wireless power transfer converter systems for EV applications using MATLAB/ Simulink. International Journal of Innovative Technology and Exploring Engineering, 2019. Vol 8(5), p. 406-409.
- [5] Chirag Panchal, Sascha Stegen, Junwei Lu. Review of static and dynamic wireless electric vehicle charging system. Engineering Science and Technology, an International JournalIn: Griffith School of Engineering, Australia: June 2018. p. 923–932.
- [6] Abhishek Bohare. Design and Implementation of Wireless Power Transmission via Radio Frequency. IJRAR, June 2019. Vol 6, p. 607-612.
- [7] Mohammad Etemadrezaei, Muhammad H. Rashid, Ph.D. Wireless Power Transfer. POWER ELECTRONICS HANDBOOK, 4th ed, 2018. p. 711–721.
- [8] Chun T. Rim, “The development and deployment of on-line electric vehicles (OLEV),” in Proc. IEEE Energy Conversion Congress and Exposition (ECCE), September 2013.
- [9] J. Huh, S.W. Lee, W.Y. Lee, G.H. Cho, and Chun T. Rim, “narrow-width inductive power transfer system for on-line electrical vehicles (OLEV),” IEEE Trans. on Power Electron. December 2011. vol. 26, no. 12, pp. 3666–3679.
- [10] Naoui Mohamed , Flah Aymen , Mohammed Alqarni , Rania A. Turkey , Basem Alamri , Ziad M. Ali , Shady H.E. Abdel Aleem. A new wireless charging system for electric vehicles using two receiver coils. Ain Shams Engineering Journal August 2021.
- [11] Sumer S. Hardan, Haroutuon A. Hairik, Rabee' H. THEjeel. Matlab/Simulink-Based Modeling of Typical Inductive Power Transfer (IPT) System. 6th IEEE International Energy Conference (ENERGYCON). 2020. P. 86–92.
- [12] Eugen Coca. Wireless Power Transfer: Fundamentals and Technologies. ExLi4EvA, June 2016. P 27-48.
- [13] Cédric Lecluyse, Ben Minnaert, Michael Kleemann. A Review of the Current State of Technology of Capacitive Wireless Power Transfer. Energies MDPI, September 2021.
- [14] Kim, S., Pakzad, S., Culler, D., Demmel, J., Fenves, G., Glaser, S., Turon, M. Health Monitoring of Civil Infrastructures using Wireless Sensor Networks. 6th International Symposium on Information Processing in Sensor Networks, 2007. p. 254–263.
- [15] Guidelines for limiting exposure to time-varying electric and magnetic fields (1 Hz to 100 kHz). International Commission on Non-Ionizing Radiation Protection. Health Phys. December 2010. Vol 99, issue 6, p. 818–836.
- [16] Michele Cincera, Rainer Frietsch, Jos Leijten, Carlos Montalvo, Anita Pelle, Christian Rammer, Andrea Renda, Torben Schubert, Reinhilde Veugelers The Impact of Horizon 2020 on Innovation in Europe, 2020.
- [17] Virtanen H., Keshvari J., and Lappalainen R. The effect of authentic metallic implants on the SAR distribution of the head exposed to 900, 1800 and 2450 MHz dipole near field. Phys. Med. Biol. 2007. vol. 52, p. 1221–1236.
- [18] González-González, J.M., Triviño-Cabrera, A., Aguado, J.A., González-González, J.M., Triviño-Cabrera, A., Aguado, J.A. Design and validation of a control algorithm for a SAE J2954-compliant wireless charger to guarantee the operational electrical constraints. Energies, 2018.
- [19] Ali Abdolkhani. Fundamentals of Inductively Coupled Wireless Power Transfer Systems. June 2016. DOI: 10.5772/63013
- [20] Keeling N.A, Covic G.A, Boys J.T. A Unity-Power-Factor IPT Pickup for High-Power Applications. IEEE Transactions on Industrial Electronics. 2010, p. 744–751.
- [21] R. Walli. ORNL surges forward with 20-kilowatt wireless charging for vehicles. February 2016.