

# Design of a Supervisor of Electric Power Generation Units by a Multivariable Neural System

G. Ramanantena<sup>1</sup>, Yvon. D. Andrianaharison<sup>2</sup>

<sup>1</sup>PhD Student, Doctoral School in Sciences and Techniques of Engineering and Innovation (ED-STII),  
University of Antananarivo, Madagascar. E-mail : [ramagilbert@yahoo.fr](mailto:ramagilbert@yahoo.fr)

<sup>2</sup>Thesis Director, ED-STII, University of Antananarivo, Madagascar.

**Abstract :** *In the recent years, fuzzy logic supervisor has been used widely for hybrid electric power generation units connected to the power systems or isolated. In this paper, we create a supervision based on the artificial neural networks. This supervisor coordinates the operation of the electric power generation units connected to the interconnected power system. These units consist of a Diesel power plants and three hydroelectric power plants. In real-time, this supervisor provides the reference powers to the electric power generation units connected to the interconnected power system. The results obtained, using the simulation, show us that the artificial neural network supervisor's performance are satisfactory.*

**Keywords :** artificial neural network supervisor (ANNS), hydroelectric power plants (HPP), mean square error (MSE), number of hidden neurons, region DIANA.

## 1. INTRODUCTION

Madagascar has three interconnected power systems (IPS) : interconnected power system of Antananarivo (RIA), interconnected power system of Toamasina (RIT) and interconnected power system of Fianarantsoa (RIF). Currently, the region DIANA does not have an IPS. This region is located in extreme north of the island of Madagascar (12°16' South latitude, 49°17' East longitude) [1]. It has great potential in renewable energy (wind, solar, hydraulic). We study the operation of the three HPP (Ampandriambazaha, Andranomamofona and Bevory) of 77 MW in the IPS this region. This involved sizing the high-voltage (HV) power transmission lines that could link five districts in this region to supply them with electricity. The results obtained in [1] show us that the operation of the three HPP can operate for twenty-nine years and the voltage levels of 220 kV and 90 kV are well suited to the operation of the IPS.

Many research works are proposed in the literature reviews concerning the supervision of hybrid electric power generations (EPG) systems based on fuzzy logic (FL) for more than decades. L. Chalal deals with the supervision of multisource systems integrating renewable production resources [2] ; V. Courtecuisse, S. Breban, M. Nasser, P. A. Vergnol, B. Robyns and M. Radulescu develop the strategy supervision based on FL for a hybrid generator (HG) composed of wind turbine (WT), micro hydropower plant (MHPP) and energy storage system (ESS), connected to the electric power system [3]. A proposed FL supervisor allows to maintain the reference power and to contribute in the primary frequency control (PFC) ; the work of S. P. Ngoffe, A. M. Imano and S. N. Essiane relates to the optimization of an FL supervisor applied to the hybrid system Photovoltaic-Diesel Generators [4] ; F. Alkhalil deals with the methodology of multilevel supervision of hybrid systems (gas microturbines and photovoltaic power plant) associated with the short-term storage system, connected to an electric power system [5] ; and in 2011, M. Nasser offers the supervision of the wind-hydropower hybrid power generation sources in interconnected or isolated power systems [6]. It should be noted that S. E. Younci, M. Jraidi, N. Hamrouni and A. Cherif also study the control and supervision of the hybrid multisource system based on the artificial neural networks (ANN) [7]. The goals manage the energy transfer between the hybrid system and the alternating current (AC) grid, optimize the use of wind energy and reduce the fuel of the Diesel Generator.

In this paper, the goal of our work is to create of a supervisor based on the artificial neural networks (ANN). This supervisor sends control signals in the form of reference powers to the various EPG units connected to the IPS in order to ensure the stability of the IPS. The different EPG consists of three hydroelectric power plants (HPP) and a Diesel power plant (DPP). After this introduction, this paper contains the following sections : in Section 2, we describe the used material and the proposed method ; then, Section 3 presents the simulation results and discussion ; and finally, we present the conclusions of the paper in Section 4.

## 2. MATERIALS AND METHODS

The used material in this section is defined in the Fig.1 and this figure represents the interconnected power system (IPS) of the region DIANA :

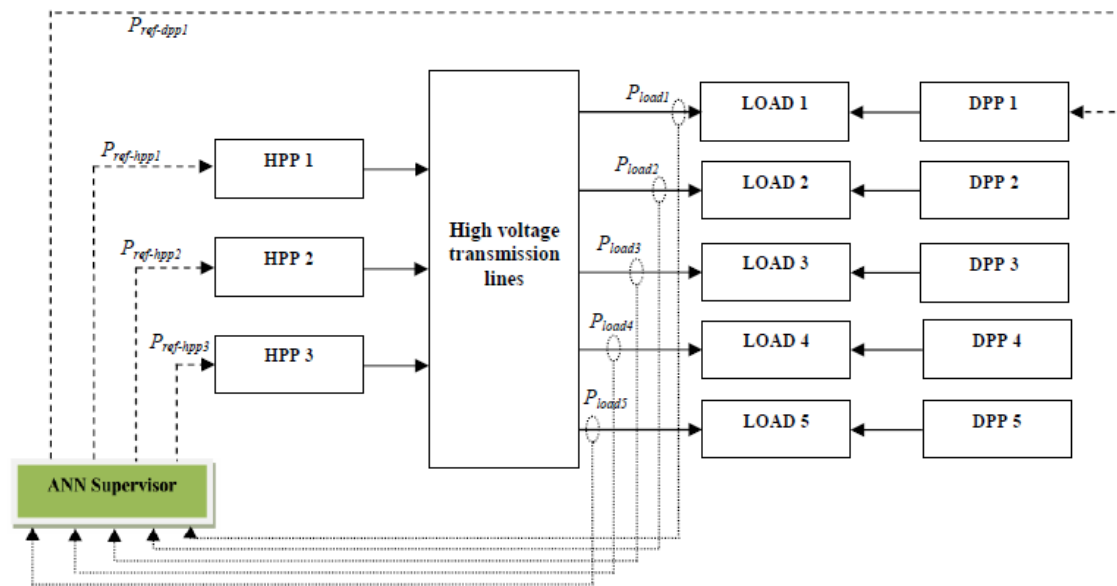

Fig. 1. Structure of IPS the region DIANA

Fig.1 is mainly composed of :

- An ANN Supervisor ;
- Three hydroelectric power plants (HPP  $i$ , with  $i = \overline{1,3}$ ) ;
- Five Diesel power plants (DPP  $j$ , with  $j = \overline{1,5}$ ) ;
- High-voltage (HV) transmission lines to transport the electrical energy produced ;
- Five consumptions (LOAD  $k$ ,  $k = \overline{1,5}$ ) which are supplied by DPP.

This IPS is managed by an ANNS.

### 2.1 Presentation of ANN Supervisor

The ANN Supervisor (ANNS) manages the EPG units. It receives information on the load side such as the measured active powers. And at the time, it gives the control signals in the form of reference powers for the HPP as well as the Diesel power plant type DPP1. The ANNS is a multivariable neural system (MNS) :

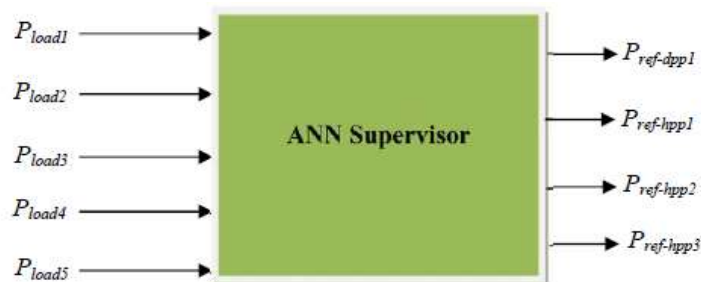

Fig. 2. Structure of ANN Supervisor

The different variables of the MNS are :

- Input variables :  $P_{load1}$  represents the power measured at load  $n^{\circ}1$  ;  $P_{load2}$  which is the power measured at the second load ;  $P_{load3}$  the measured load power the number 3 ;  $P_{load4}$  the fourth load power supplied by the DPP 4 plant ;  $P_{load5}$  is the power measured at load  $n^{\circ}5$  ;

- Output variables :  $P_{ref-dpp1}$  represents the reference DPP 1 power ;  $P_{ref-hpp1}$  represents the reference HPP 1 power ;  $P_{ref-hpp2}$  is the reference HPP 2 power ;  $P_{ref-hpp3}$  is the reference power that drives HPP 3.

In this paper, the proposed method is the artificial intelligence technique that is to say artificial neural network (ANN).

## 2.2 Artificial neural network

An artificial neural network (ANN) is a new means of processing information inspired by the functioning of biological neurons. By analogy with the electrochemical model of the biological neuron, the modeling of an artificial neuron is illustrated in the figure below [8] :

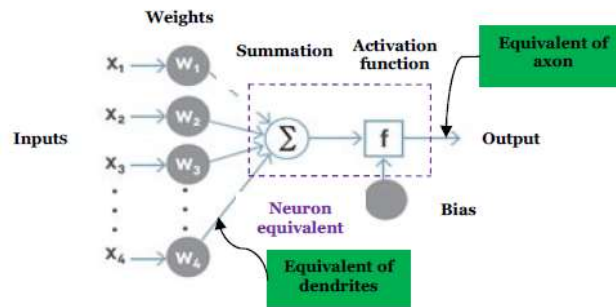

Fig. 3. Diagram of an artificial neuron model

The mathematical formula of the neuron output is given by [9] :

$$\text{output} = f(x) \text{ with } x = \sum_{i=1}^n w_i \cdot x_i + b \tag{1}$$

where  $x$  is the activation state ;  $b$  is the neuron bias ;  $f$  is the activation function of the neuron ;  $w_i$  is the connection weight of the neuron.

We can solve the MNS for the multilayer perceptron neural networks [9]. In our case, we have the following three layer neural networks :

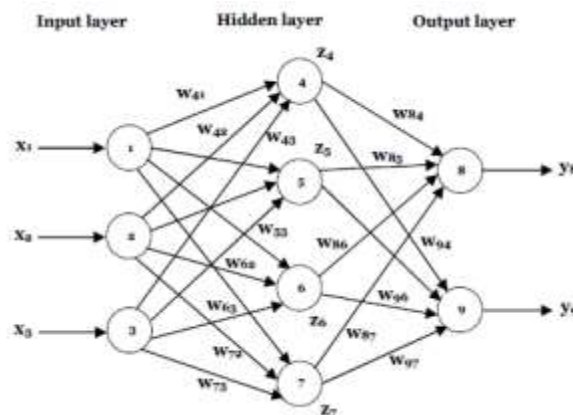

Fig. 4. Multilayer perceptron neural networks

It possible to define matrix relations that link the input vector  $x$  and output vector  $y$  :

$$\begin{bmatrix} y_8 \\ y_9 \end{bmatrix} = \begin{bmatrix} w_{81} & w_{82} & w_{83} \\ w_{91} & w_{92} & w_{93} \end{bmatrix} \cdot \begin{bmatrix} x_1 \\ x_2 \\ x_3 \end{bmatrix} \quad (2)$$

with

$$w = \begin{bmatrix} w_{81} & w_{82} & w_{83} \\ w_{91} & w_{92} & w_{93} \end{bmatrix} = \begin{bmatrix} w_{84} & w_{85} & w_{86} & w_{87} \\ w_{94} & w_{95} & w_{96} & w_{97} \end{bmatrix} \cdot \begin{bmatrix} w_{41} & w_{42} & w_{43} \\ w_{51} & w_{52} & w_{53} \\ w_{61} & w_{62} & w_{63} \\ w_{71} & w_{72} & w_{73} \end{bmatrix}$$

where w is the synaptic weight matrix.

### 2.3 Calculation of the number of neurons in the hidden layer

In this subsection, the formula for determining the number of neurons in the hidden layer is proposed. There is no tool analytical allowing to know the ideal number of hidden neurons. They do the most often by trial and error although some authors have proposed some rules : in this regard, A. J. Maren, C. T. Harston and R. M. Pap [10] have suggested that, in the majority of applications, the optimal number of neurons in the hidden layers is greater than or equal to the number of input neurons. And according to B. Wierenga and J. Kluytmans in [11], the size of the hidden layer had to be equal the size of the input layer. In [12], R. Hecht-Nielsen suggested not to exceed the following limit :

$$N_h \leq 2.N_i + 1 \quad (3)$$

So, we can define and determine the value of the number of hidden neurons from the following formula :

$$N_i \leq N_h \leq 2.N_i + 1 \quad (4)$$

where  $N_i$  : number of neurons in the input layer ;  $N_h$  : number of neurons in the hidden layer.

## 3. RESULTS AND DISCUSSION

### 3.1 Design of ANNS model

The design of a neural model includes the following steps [13], [14] :

- Determining the inputs and outputs ;
- Collecting the data necessary for learning ;
- Determining the number of neurons in the hidden layers necessary to obtain a satisfactory approximation ;
- Carrying out the learning ;
- Evaluation of the performance of the neural network at the end of the training.

The input parameters of the ANN are based on the data of the evolution of the power of each district. The output parameters of the ANN are the reference powers of the HPP and that the DPP supplying load n°1.

Thirty-seven samples were taken into consideration.

The third step is to determine the number of neurons in the hidden layer.

We used the Neural Network Toolbox under Matlab to perform the calculation. The table below shows the choice of the number of neurons in the hidden layer after several learning test :

**Table 1:** Determination of the configuration of the ANN according to the number of neurons and the Mean Square Error (MSE)

Test number	Hidden layer	Number of neurons per hidden layer	Mean Square Error (MSE)
1	1	5	$4.74 \cdot 10^{-8}$
2		6	$4.14 \cdot 10^{-8}$
3		7	$2.99 \cdot 10^{-8}$
4		8	$3.86 \cdot 10^{-8}$
5		9	$3.28 \cdot 10^{-8}$
6		10	$1.10 \cdot 10^{-7}$
7		11	$6.58 \cdot 10^{-8}$

Table 1 shows us that a number of seven neurons in the hidden layer is optimal because the value of the corresponding MSE is minimal compared to the other neurons, that is to say  $2.99 \cdot 10^{-8}$ . Therefore, the size of the configuration of the ANN for the supervision of the EPG units is (5-7-4).

During the training phase, the curves obtained are presented in Fig.5 to Fig.6 :

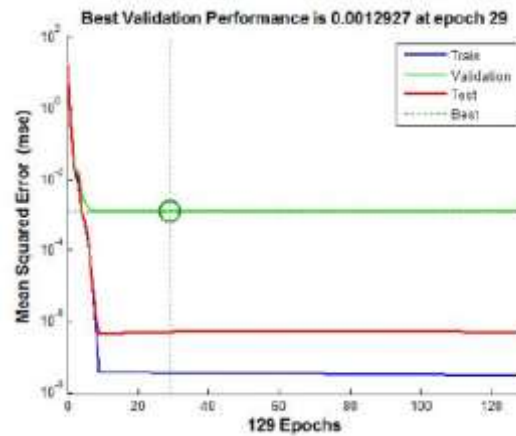

**Fig. 5.** Performance plot for one hidden layer with (5-7-4) configuration

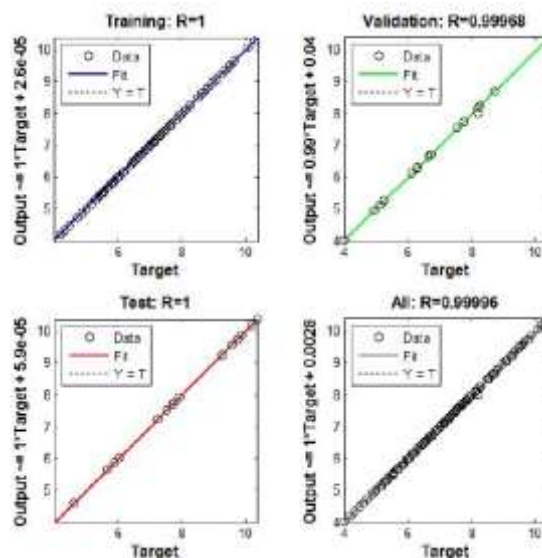

**Fig. 6.** Linear regression of the ANN (5-7-4)

According to Fig.5, the best execution of the MSE for the validation step by ANN (5-7-4) is 0.0012927 at twenty-nine iterations. This value remains constant until 129 iterations. Our learning phase is done during one hundred and twenty-nine iterations and the error MSE starts from  $10^{-2}$  to  $10^{-8}$ .

For Fig.6, the linear regression values for three steps (Training, Validation and Test) of our ANN are (1 ; 0.99968 ; 1). These confirm that the ANN (5-7-4) is reliable. Finally, Fig.7 shows the architecture of the ANN with a hidden layer for be able to model the supervision of EPG units connected to The IPS.

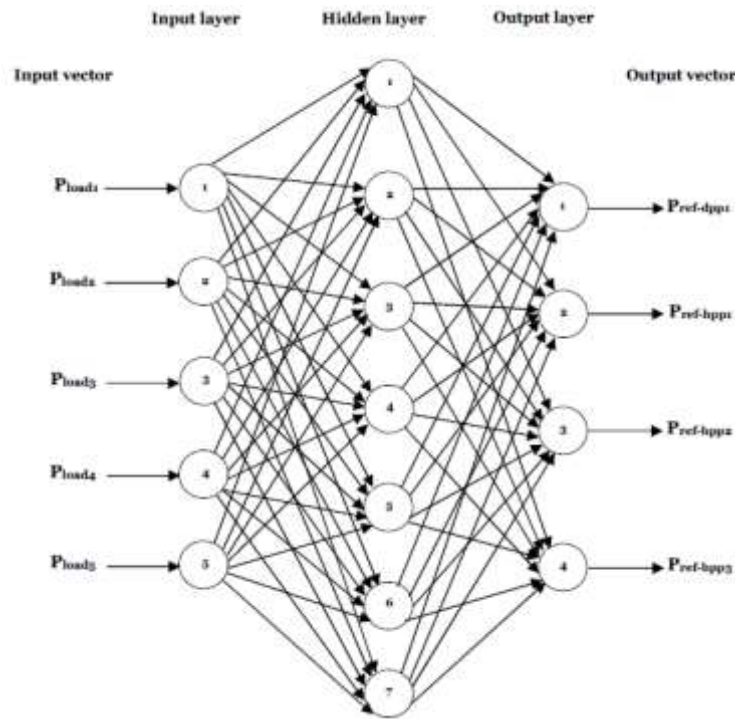

Fig.7. Structure of the ANN with configuration (5-7-4) applied to supervision

This neural network, according to Fig.7, is made up of three layers, namely :

- An input layer with five neurons represents the powers requested by the loads ;
- A hidden layer with seven neurons with a linear activation function ;
- An output layer with four neurons represents the reference EPG powers for the power plants with a linear activation function.

### 3.2 ANNS simulation

Once the ANN is build and its training has reached satisfactory performance, we now move on to the testing stage. This test phase will take place in the Simulink. The architecture structure of the ANN (5-7-4) illustrated in Fig.7 can represent under the Simulink according to the following Fig.8 :

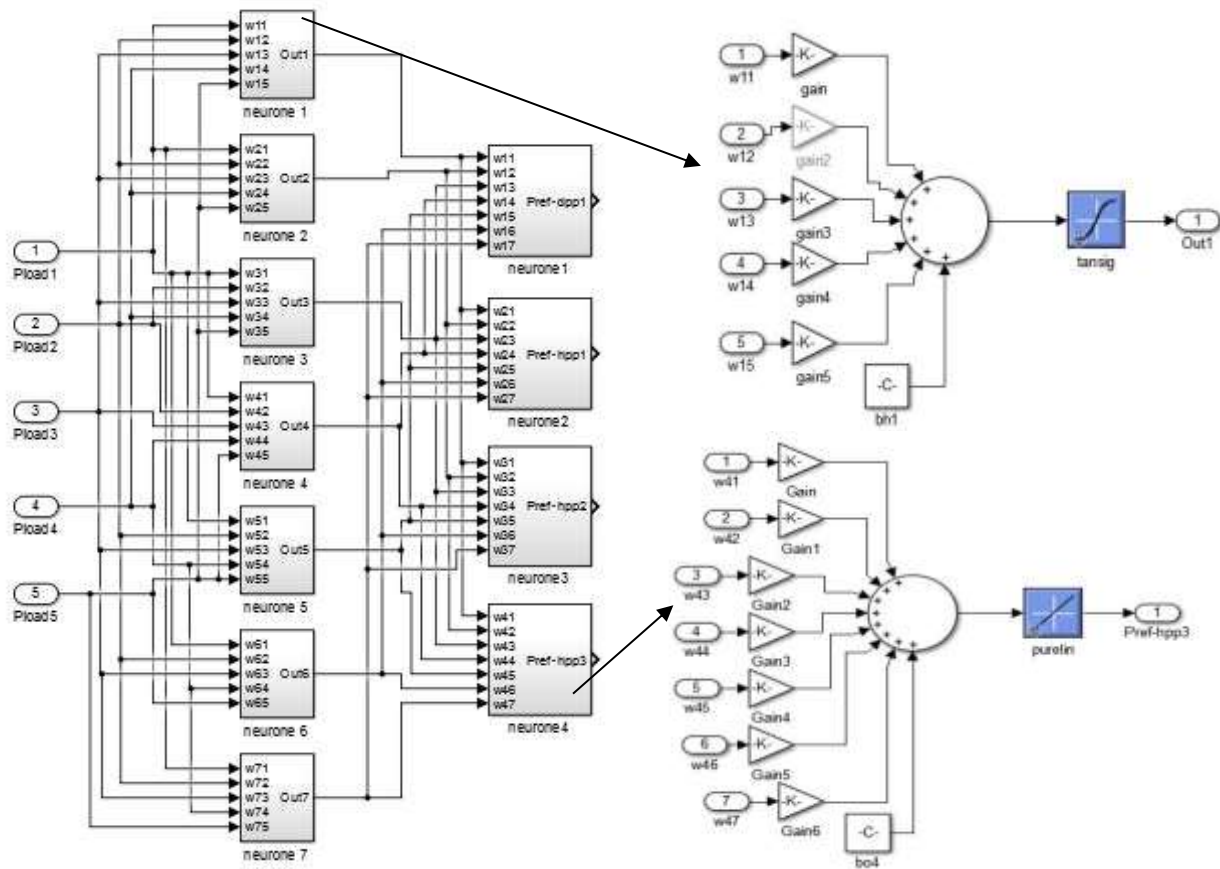

Fig. 8. Structure of the ANNS in Simulink

The structure of the ANNS consists of three parts :

- The first part is the input to the neural network which represents the vector of active powers for the five different areas ;
- The second part is the hidden layer with seven neurons. Each neuron constitutes five inputs and four outputs to connect to the output layer ;
- The last is the output layer with four neurons. This part allows communication to the external environment of the ANNS.

The results of ANNS simulations are shown in Fig.9 and Fig.10. Fig.9 represents load profile at the ANNS inputs and the Fig.10 represents profile of the reference powers at the ANNS outputs. At  $t = 0$  to 4 s, for Fig.9, we have the following powers at the inputs of the supervisor :  $P_{load1} = 14.250$  MW,  $P_{load2} = 0.177$  MW,  $P_{load3} = 1.587$  MW,  $P_{load4} = 1.920$  MW and  $P_{load5} = 8$  MW. After simulation, the reference powers obtained, according to Fig.10, at the outputs of the ANNS are :  $P_{ref-dpp1} = 3.038$  MW,  $P_{ref-hpp1} = 10.710$  MW,  $P_{ref-hpp2} = 4.877$  MW,  $P_{ref-hpp3} = 4.147$  MW. These reference powers remain stable during time  $t = 0$  to 4 s. For  $t = 4$  to 7 s, the load powers  $i$  ( $i$  ranging from 1 to 4) remain constant according to the previous values ; but the power of load 5 increased by 2,240 MW. In this case, the value of this power becomes  $P_{cha5} = 10.240$  MW. The results at the outputs of the supervisor are  $P_{ref-cha1} = 3.134$  MW;  $P_{ref-cha2} = 10.75$  MW;  $P_{ref-cha3} = 4.925$  MW and  $P_{ref-cha4} = 4.157$  MW. At  $t = 8$  to 10 s, the values at the supervisor's inputs are constant ( $P_{load1} = 10$  MW,  $P_{load2} = 0.177$  MW,  $P_{load3} = 1.578$  MW,  $P_{load4} = 1.920$  MW). But the power of load 5 dropped by 4 MW. Therefore, the latter becomes  $P_{load5} = 6.240$  MW. The results obtained at the outputs of the ANNS are  $P_{ref-dpp1} = 3.054$  MW,  $P_{ref-hpp1} = 10.713$  MW,  $P_{ref-hpp2} = 4.963$  MW and  $P_{ref-hpp3} = 4.262$  MW.

In the time interval, whatever the load power values at the input of ANNS, the reference powers at the output of ANNS remain constant and without oscillation.

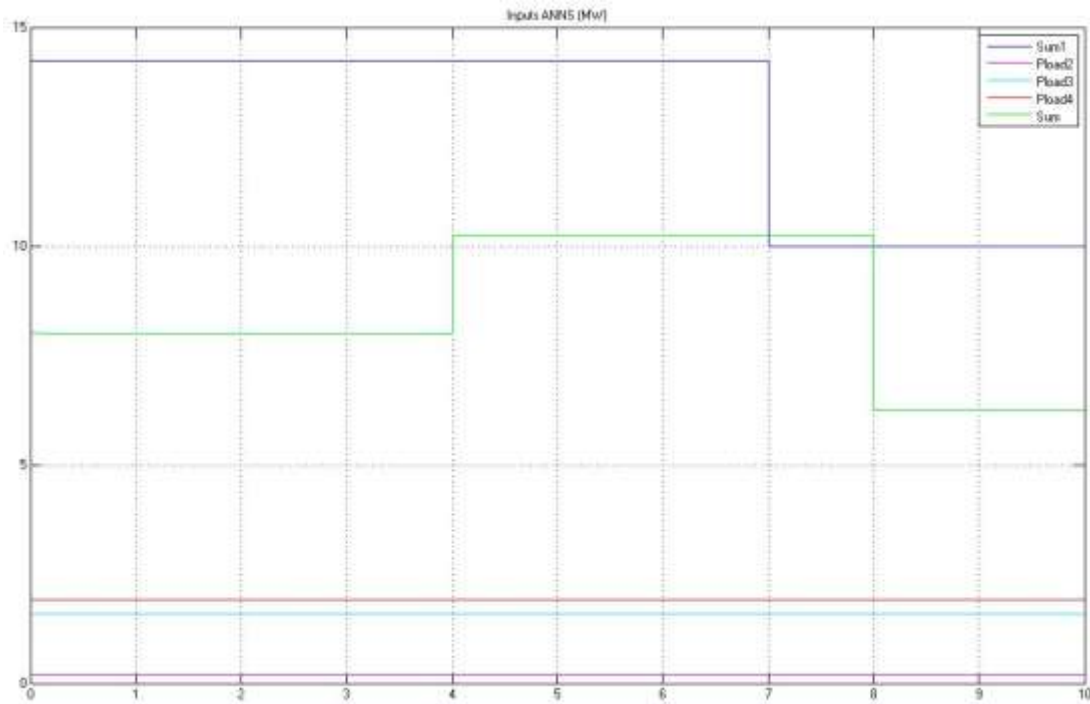

Fig. 9. Load profile at the ANNS inputs

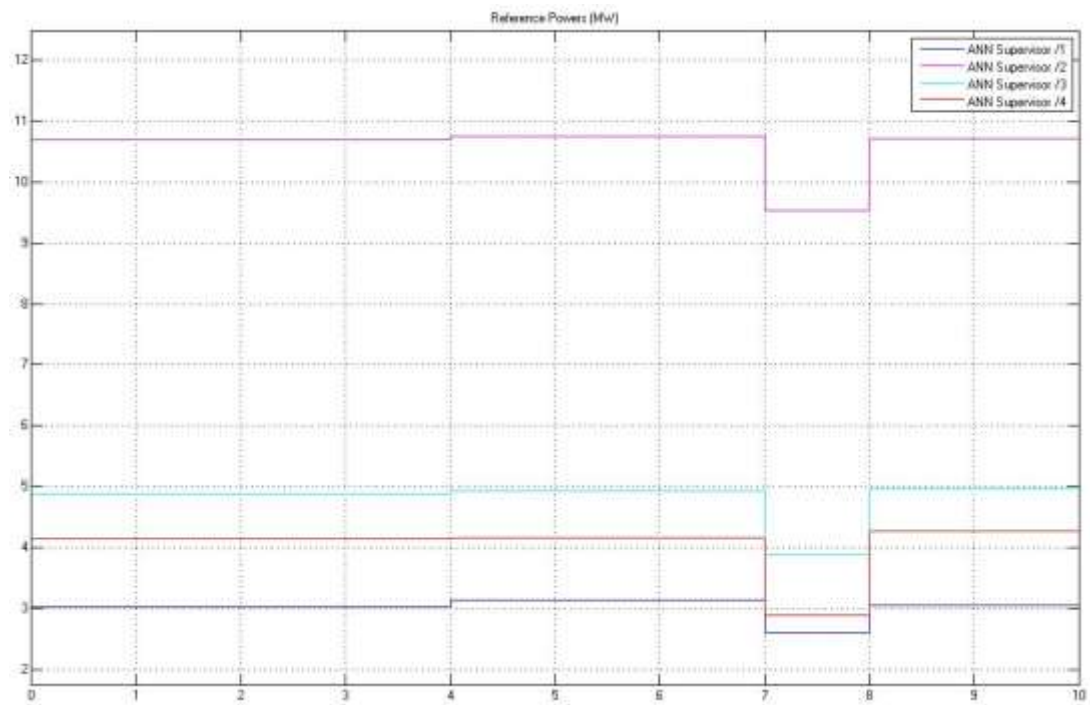

Fig.10. Profile of the reference powers at the ANNS outputs



#### 4. CONCLUSION AND FUTURE WORKS

In this paper, we have proposed a supervisor of electric power generation units connected to the power system as well as the formula for determining the number of neurons in the hidden layer. This supervisor is based on an artificial neural network. The performance of this supervisor has been shown using simulation in Simulink. The simulation results, in real-time, are satisfactory because the ANN Supervisor can supply the reference powers.

Future works will apply to the interconnected power systems of the region DIANA [1] in order to participate in secondary frequency control in automatic mode.

#### 5. ACKNOWLEDGMENT

This publication is the result of research works carried out at the Doctoral School in Sciences and Techniques of Engineering and Innovation (ED-STII) of the University of Antananarivo, Madagascar. The corresponding author would like to thank Prof. Paul A. Randriamantsoa, Director of the ED-STII, for having welcomed him to this Doctoral School. In particular, he would like to thank Prof. Yvon Andrianaharison, Thesis Director, for his supervision, advice and encouragement.

#### 6. REFERENCES

- [1] G. Ramanantena, "Conception et étude de fonctionnement du réseau interconnecté. Cas du réseau de la région DIANA", Mémoire de Mastr à visée de Recherche, Université d'Antananarivo, 23 avril 2018.
- [2] L. Chalal, "Coordination de système multisources pour favoriser la production d'énergie électrique renouvelable," Doctoral Dissertation, Université de Lille, 14 mars 2013.
- [3] V. Courtecuisse, S. Breban, M. Nasser, A. Vergnol, B. Robyns et M. Radulescu, "Supervision d'une centrale multisources basée sur l'association éolien, micro hydraulique et stockage d'énergie", *Electrotechnique du futur 2007-07 septembre* – Toulouse-France, pp. 1-8.
- [4] S. P. Ngoffe, A. M. Imano et S. N. Essiane, "Optimisation d'un superviseur flou par la méthode des couloirs : Application à la supervision d'un système Photovoltaïque-Diesel", *Symposium de Génie Electrique, 7-9 juin 2016*, Grenoble, France.
- [5] F. Alkhalil, "Supervision, économie et impact sur l'environnement d'un système d'énergie électrique associé à une centrale photovoltaïque", Ph.D Dissertation, Ecole Nationale Supérieure d'Arts et Métiers, 24 novembre 2011.
- [6] M. Nasser, "Supervision de sources de production d'électricité hybrides éolien-hydraulique dans les réseaux d'énergie interconnectés ou isolés", Thèse de Doctorat, Ecole Nationale Supérieure d'Arts et Métiers, 05 mai 2011.
- [7] S. E. Younci, M. Jraidi, N. Hamrouni and A. Cherif, "Artificial Neural Network Control of Hybrid Renewable Energy System Connected to AC Grid", *International Journal of Computational Intelligence Techniques, Vol. 2, 2011, pp. 44-52*.
- [8] N. Toulon, "Deep Learning et agriculture," AgroTIC, Bordeaux, novembre 2018.
- [9] D. E. Chaouch, "Contrôle robuste des systèmes dynamiques non linéaires incertains par des approches de l'intelligence artificielle," Ph.D Dissertation, Université des Sciences et de la Technologie d'Oran Mohamed Boudiaf, 20 novembre 2016.
- [10] A. J. Maren, C. T. Harston and R. M. Pap, "Handbook of Neural Computing Applications", Academic Press, London ISBN 0-12-471260-6, 1990.
- [11] B. Wierenga, J. Kluytmans, "Neural Nets Versus Marketing Models in Time Series Analysis : A Simulation Study", *In Proceedings of the 23th Annual Conference of the European Marketing Acaademy*, Maastricht, The Netherlands, 17-20 May 1994, pp. 1139-1153.
- [12] R. Hecht-Nielsen, "Neurocomputing : Picking the Huma Brain", *IEEE Spectrum, Volume 25, Issue 3, March 1988, pp. 36-41*.
- [13] Y. Houam, "Commande multiobjectif en utilisant les inégalités matricielles linéaires et les algorithmes génétiques", Mémoire de Magister, Université Mohamed Biskra, 02 mai 2013.
- [14] D. Hassani, "Méthode des réseaux de neurones pour le calcul des paramètres pertinents des phénomènes de transports", Doctoral Dissertation, Université des Sciences et de la Technologie Houari Boumediene, 05 avril 2009.

### Authors



**Gilbert Ramanantena** received the Engineer degree in Industrial Maintenance and Energy (TAM) from Higher Institute of Technology (IST-D) of Antsiranana, Madagascar, in 2003. He also received the Master degrees in Applied Physics, specialization : Energetic, from the Faculty of Sciences and Electrical Engineering from Higher Polytechnic School (ESPA) in 2015 and 2018, respectively, of the University of Antananarivo, Madagascar. He worked in various Malagasy industrial companies from 1999 until 2011. Since 2018, he is physics teacher at High School Andohalo in Antananarivo. His research interests are power system control and stability ; electric power generation from renewable energy sources ; artificial intelligence applications to the power systems.



**Yvon D. Andrianaharison** graduated in Electrical Engineering. He is the head the Centre for Studies of Electrical Power Systems and Associated System (CERESA). Currently, he is Full Professor in the Department of Electrical Engineering at Higher Polytechnic School (ESPA) of the University of Antananarivo. His field interests include automatic, high voltage engineering, artificial intelligence, industrial systems, and dynamics of atmosphere.