

Design and Optimization of Image Compression Algorithm using Wavelet Transform for Satellite Imagery

Nolan Samraj Godwin David Sounder¹, Taiwo Samuel Aina², Uyi Aiyudubie Samson³ Oluwaseun Olanrewaju Akinte⁴, Adetola John Awelewa⁵

¹⁻²School of computer Science and Technology, University of Bedfordshire, United Kingdom

³Department of Telecommunication Engineering Air Force Institute of Technology, Kaduna, Nigeria

⁴Department of Energy and Materials Engineering, Rajamangala University of Technology, Thailand

⁵Department of Computer Science, Harvarde College of Science Business and Management Studies, Nigeria

Abstract: *The aim of this research is to develop an image compression system as part of a new satellite imaging photography transmission system. The wavelet transform has been used to build the picture compression technique in this research. The design presented and explained a thorough schematic model of the forward wavelet transform applied to images with only one decomposition level using only the operator symbols for filtering and downsampling. A thorough schematic diagram of the inverse wavelet transform utilised for reconstruction of pictures with only one synthesis level was also shown and explained using only the operator symbols for filtering and upsampling. The number of operations required for approximation of an image of size 512 x 512 pixels was calculated, as well as the schematic diagram for deploying the wavelet transform with three iterations (decomposition levels) to images shown. Every step of the computations is given on how the downsampling operator can reduce the number of operations, assuming that the wavelet filters employed in the process have four coefficients. The mean squared error of 378.6702 was obtained using MATLAB source code for image approximation.*

Keywords: Image compression, Wavelet transform, Downsampling, Upsampling, Image approximation, *discrete cosine transforms (DCT), satellite imaging*

1.0 INTRODUCTION

Image compression has become a necessity as a result of the increased traffic created by multimedia information and computerised forms of image representation [1][2]. Uncompressed image data requires significant storage capacity and transmission bandwidth [1], according to research. Image compression is a data compression technology that is used in digital images to minimise redundant information and provide a more efficient format for storing and transmitting data [3][4]. The fact that neighbouring pixels are connected and hence contain duplicate information is a common feature of most images [5][6]. Image compression can be accomplished using a variety of techniques, including the Discrete Cosine Transform (DCT) and the Wavelet Algorithm Transform (DWT) [7][8]. The primary purpose of picture compression is to lower the bit rate required for transmission or storage while preserving acceptable fidelity [1]. There are two types of image compression: lossless and lossy. Lossless compression is a type of data compression algorithm that can completely reconstruct the original data from the compressed data [9][10]. Lossy compression, in contrast, generally uses very high compression ratios [1], but allows reconstruction to be closer to the original data. Transform-based picture compression is one of the most effective wavelet applications [1]. Wavelets are mathematical functions that divide data into distinct frequency components and then examine each component with a resolution that corresponds to its scale [11][12]. They outperform classic Fourier methods in evaluating physical signals with discontinuities and strong spikes [11]. Wavelets can achieve compression rates of up to 1:300 [1]. Wavelet transforms have a number of useful qualities for image compression applications, including multi-resolution representation, scalability, and progressive transmission [13]. There are several wavelets which include Morlet, Daubechies, Coiflets, Biorthogonal, Mexican hat, and Symlets are some of the different sizes and shapes of Wavelets [14][15]. At the same time, Wavelet can extract both spectral and temporal information from a given location [16]. Wavelet compression combines multiple compression techniques into a single algorithm detect [1]. The basic idea [10] in this research is an alternative solution for image compression algorithm based on wavelet transform for satellite imagery

1.1 BLOCK DIAGRAM OF IMAGE COMPRESSION

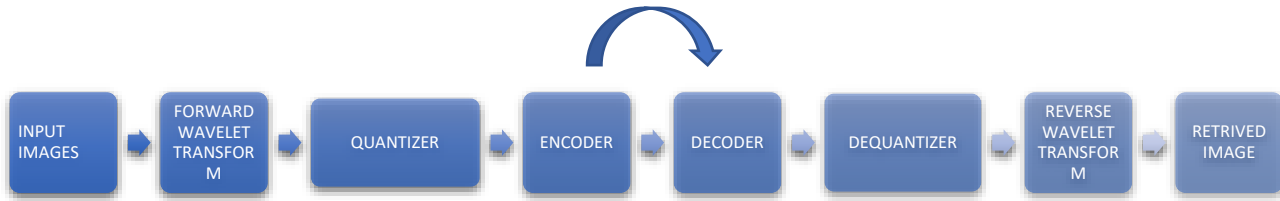

Figure 1: Block Diagram for Image Compression

The above block diagram consists of forward and inverse direction

1.1.1 Forward Direction

- **Forward Wavelet Transform:** This block compresses the data pack into small coefficients.
- **Quantizer:** Quantization performs the rounding up of the output values of the linear transform signals. It rounds up the signal and generates a continuous signal.
- **Encoder:** This block encodes the pixels of the compressed image.

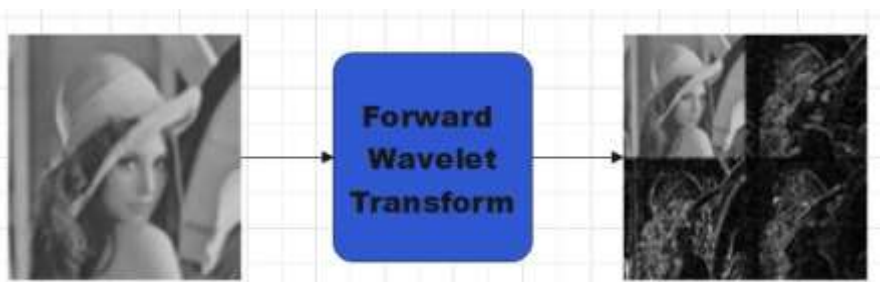

Figure 2: Forward Wavelet Transform of One Level Disposition

1.1.2 Inverse Direction:

- **Decoder:** This block decodes the encoded image.
- **Dequantizer:** Dequantizer reverts to their approximated original values of quantized image.
- **Inverse Wavelet Transform:** This block gains the estimated values of the compressed image and generates the output image.

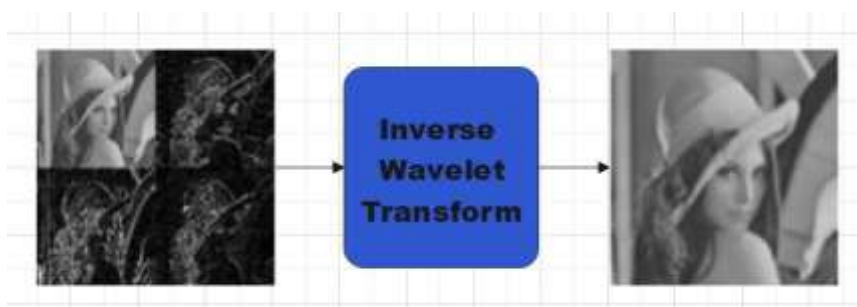

Figure 3: Inverse Wavelet Transform of One Level Synthesis

1.2 Wavelet Transforms With Filters And Operations

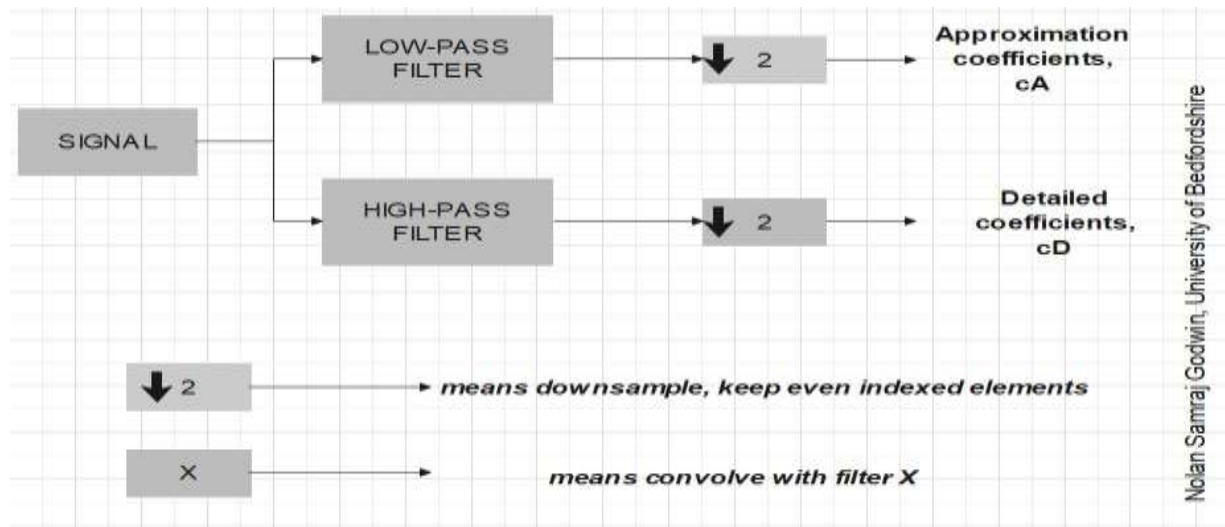

Figure 4: Forward Wavelet Transform for a Normal Signal

Let us explain and describe an average signal based on the comprehension before applying the image. The DWT is a signal with a length of N and a maximum of $\log_2 N$ stages. The signal is first convolved with a low-pass filter and a high-pass filter at the same time to yield a set of approximation coefficients and detail coefficients, respectively [18]. The coarse-scale, low-frequency components of the signal are represented by the approximation coefficients, while the fine-scale, high-frequency components are represented by the detail coefficients. We end up having twice as much data as we started with at this point. Down-sampling is used to solve this problem. This entails discarding every second data point. The final set of approximation coefficients, cA_o , and detail coefficients, cD_o , is the result [18]. A schematic diagram depicts this procedure. The Fast Wavelet Transform algorithm can be used to achieve 2D using the preceding diagram as a starting point.

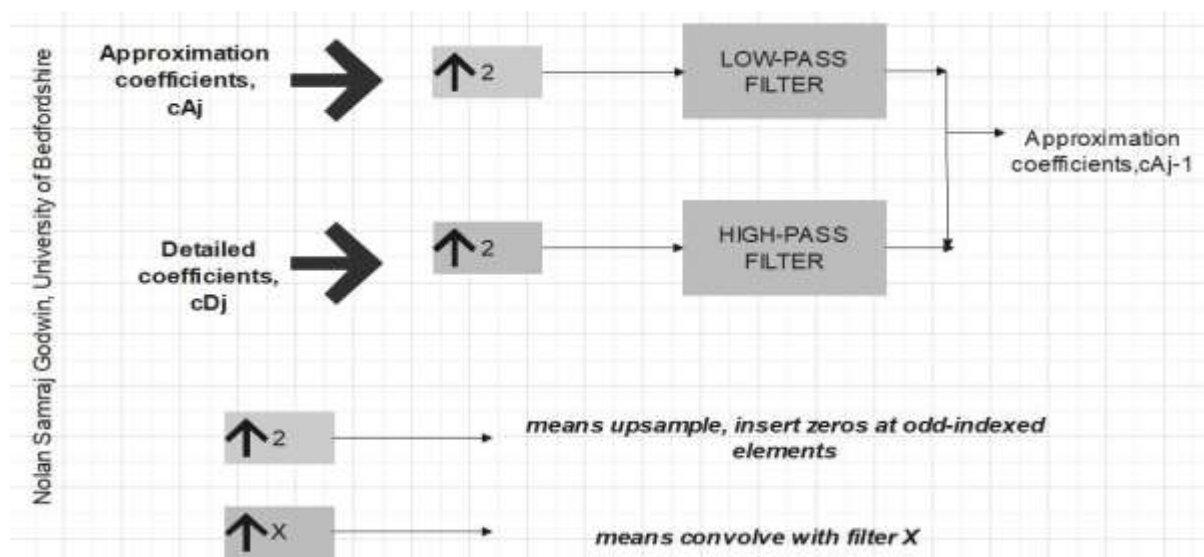
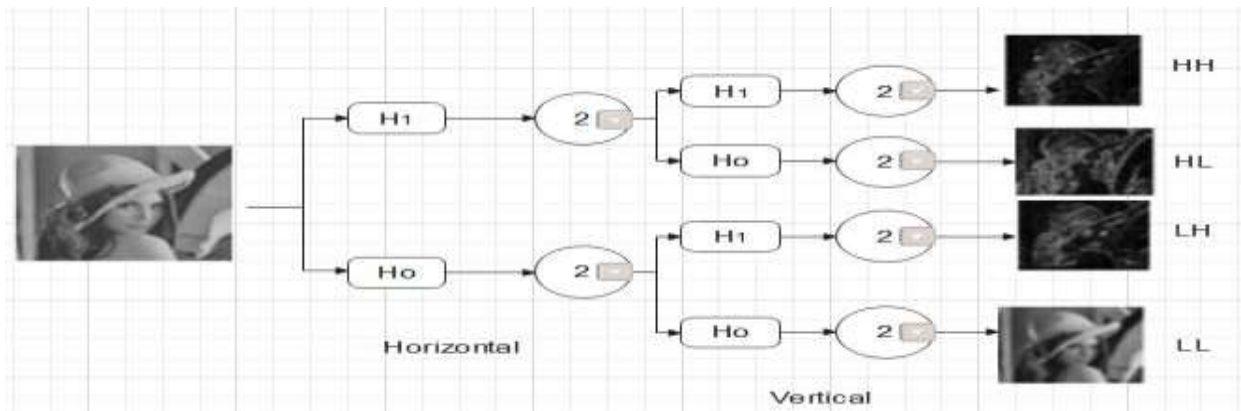

Figure 5: Inverse Wavelet Transform for a Normal Signal

It's important critical to have a technique to reassemble the original data without losing any data. This is referred to as reconstruction or synthesis. Convolution is followed by down-sampling in decomposition, while up-sampling is followed by convolution in reconstruction [18]. The practise of extending a signal by inserting zeros between the data points is known as up-

sampling. The approximation coefficients, cA_n , and detail coefficients, cD , are first up-sampled before completing the reconstruction. A low-pass filter is used to convolve the approximation coefficients, while a high-pass filter is used to convolve the detail coefficients. The next level of approximation coefficients, cA_{j-1} , is obtained by combining both sets of convolved data [18]. The procedure is depicted in the schematic picture above. The Fast Wavelet Transform algorithm can be used to perform 2D reconstruction using the schematic as a starting point.

2.0 Implementation of a single level decomposition of a $L \times H$ image size using the 2D DWT



Schematic A

First, it analyzes the image given to Lena horizontally, approximates it horizontally, and divides it into detailed versions, which is shown in Figure-2. Each output is then analyzed vertically, with two subsamplers in each part, providing results that are four times smaller than the original image. It will have four outputs after decomposition of the resulting level. One is for the low-frequency unit station (LL), which can be disassembled further, and the other is for the three comprehensive high-frequency unit roles HL, LH, and HH. The analysis stage is the method for decomposing an image.

HH: Diagonal detail

HL: Vertical detail

LH: Horizontal detail

LL: Approximate image

The forward discrete wavelet transform was used to convert Lena's original image x ; four denotes that it has been divided into subbands (LL, LH, HH, HL). Down-sampling by two is depicted in the schematic. The high-pass filter is designated by H1, while the low-pass filter is designated by H0. The wavelet transform is used to transform images both horizontally and vertically. As a result, as illustrated in the schematic-A, the operation is performed twice, horizontally and vertically.

3.0 Recovery of original image from the single level decomposition

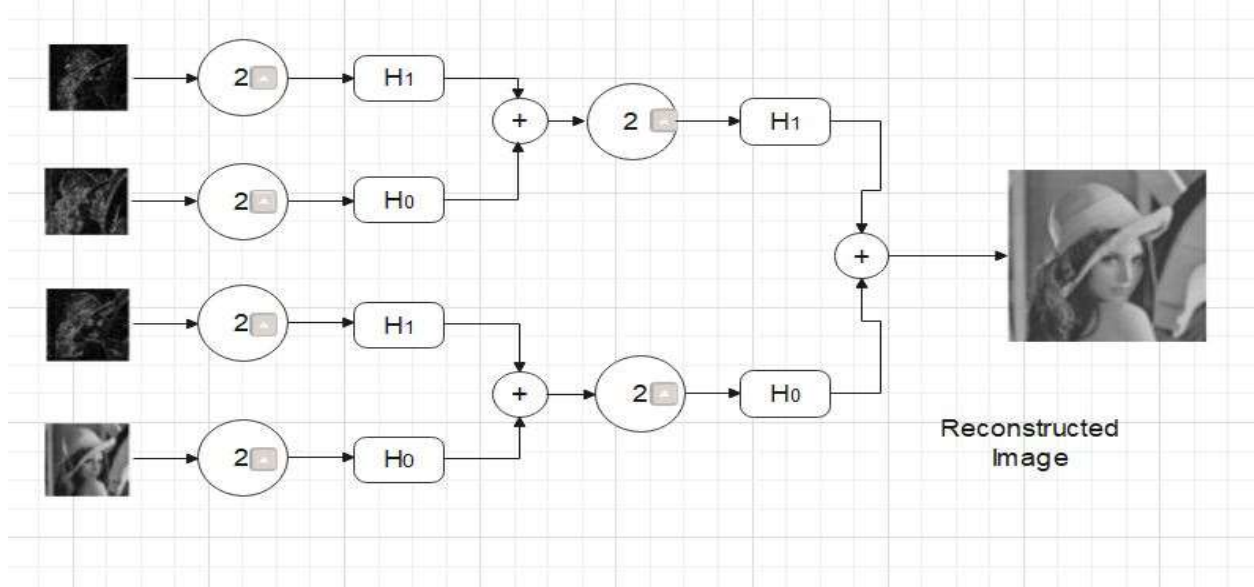

Schematic B

The four subbands containing detailed information about the picture are upsampled and filtered in the vertical and horizontal directions, as is done in the analysis step. Upsampling of a photo is the process of adding zero-valued samples between the original samples. When upsampling, it improves spatial resolution by adding undesirable spectral images to the original image. As shown in the figure, upsampling by filtering is performed to delete unnecessary spectral images. The low-level coefficients are sent through the low-pass H0 and high-pass H1 filter banks after being upsampled by a factor of two to create high-level approximation coefficients that yield distinct results. Finally, the image is reconstructed to a complete or near-complete reconstruction. This IDWT (Inverse Discrete Wavelet Transform) approach produces a higher-resolution image. The IDWT (Inverse Discrete Wavelet Transform) is used to reconstruct a nearly perfect image from the images of the four bag stations, as shown in the diagram. The station of each unit offers a wealth of information on the original image x . The synthesis stage, which is the inverse of the analysis stage, is the name given to this operation.

4.0 Wavelet transform deployment with 3 Iterations to Images

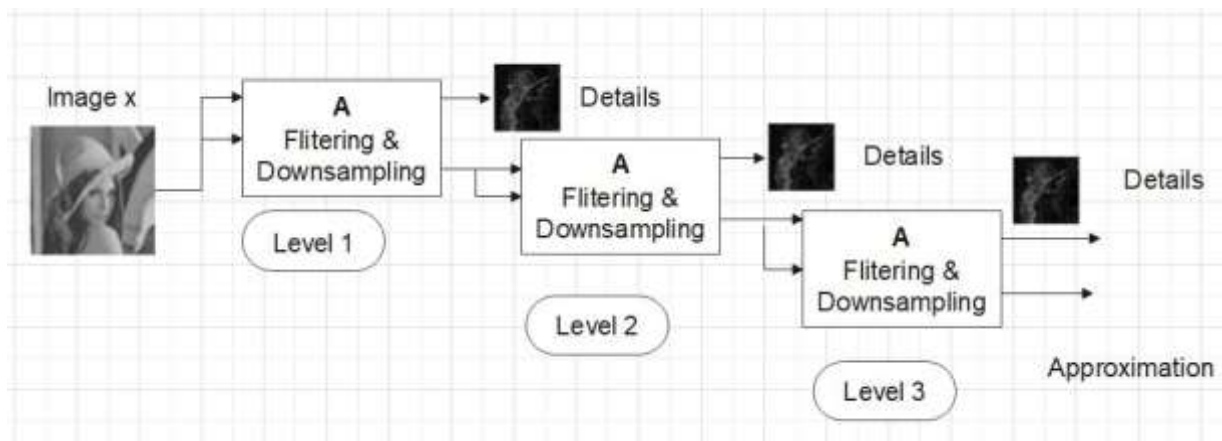

Schematic C

With detailed coefficients and approximation coefficients, decompose the wavelet image. A low pass filter approximates the signal, while a high pass filter provides information in multiple directions (horizontal, vertical and diagonal). The diagram above depicts three layers of breakdown, each employing the process illustrated in schematic A. The bass' output is used as the starting point for the next decomposition process. Filter, High Pass This parameter is used to recreate the output image. The wavelet coefficient is calculated by transferring the ripples using a filtering and down-sampling technique, as shown in circuit schematic-

A. This technique is done three times for each of the three breakdown phases. The down-sampler, the principal operator, reduces the spatial resolution of the image to obtain a closer image.

5.0 Reconstructing images using 3 iterations (decomposition levels)

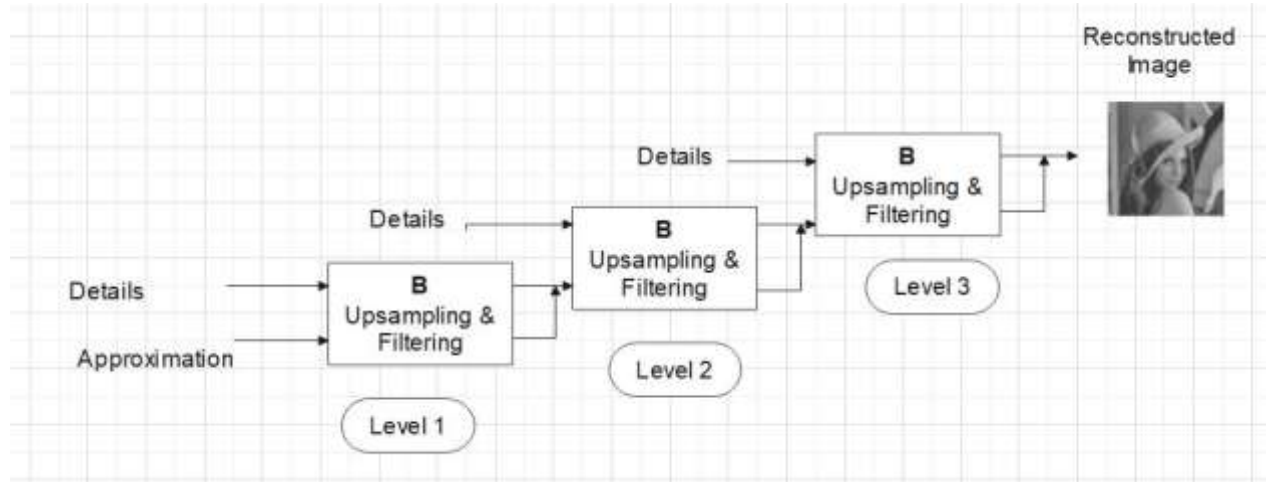

Schematic D

Sub-band reconstruction Schematic-B is often shown as one iteration level. The original image was reconstructed using the Schematic-B technique with up to three iteration levels, as shown in the figure above. As input, the wavelet coefficients for high pass and low pass are used. The low-pass output is used as input to the next step at each composing level, with more for the high-pass. The wavelet coefficients are altered to a high resolution with an appropriate quantization approach using the 2D wavelet transform method, and then inversely transformed to get an up-sampled image in the region of the original image. Based on the addition of high frequency detail, each level advances to a more acceptable image representation Progression from coarser to finer image representation. Images may be represented in other resolutions at about any level.

6.0 Image approximation

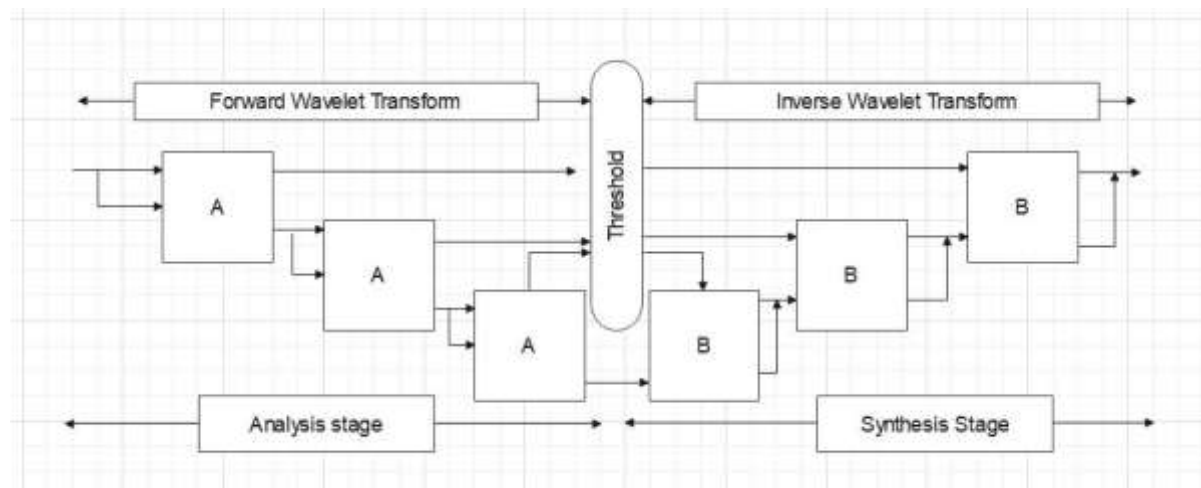

Schematic E

The forward wavelet transform is demonstrated in Schematic-C. The image is split into a high frequency and low frequency unit reverse image, which can be scaled and relocated as needed. The inverse wavelet transform is used to recreate an image using an up-sampler and a synthetic filter bank in Schematic-D. Filtering determines the image's resolution (details), while down-sampling and up-sampling determine the image's scale. After applying the forward wavelet transform, the threshold discards some coefficients (error generation) and reconstructs the station wavelet transform image. Image approximation keeps the larger coefficients but sets the smaller coefficients to zero. This approximates signal processing. A threshold is a portion of the iteration count that is zeroed at each iteration level as a result of this operation. The reconstructed image does not match the original image and does not contain the entire image. The quality of the reconstructed image is determined by errors evaluated by MSE and PSNR. After meticulous counting, tiny coefficients are removed during the decomposition phase

7.0 Calculation of Realization Problem

Input Size = 512 X 512

Wavelet Filter = 4

Mathematical Operation of DWT on an Image

Decomposition Level	Input Image Size	Analysis on Rows	Analysis on Columns	Number of Multiplications and Additions
1	$N_1 \times N_2$	$\frac{N_1}{2} \times N_2$	$\frac{N_1}{2} \times \frac{N_2}{2}$	KN^2
2	$\frac{N_1}{2} \times \frac{N_2}{2}$	$\frac{N_1}{4} \times \frac{N_2}{2}$	$\frac{N_1}{4} \times \frac{N_2}{4}$	$\frac{KN^2}{4}$
3	$\frac{N_1}{4} \times \frac{N_2}{4}$	$\frac{N_1}{8} \times \frac{N_2}{4}$	$\frac{N_1}{8} \times \frac{N_2}{8}$	$\frac{KN^2}{16}$

In this design, the size of the test image is 512 x 512 pixels,

where $N_1 = N_2 = 512$

From the table,

the resultant image after level 3 decomposition of 2D – DWT is:

$$\frac{N_1}{8} \times \frac{N_2}{8} = \frac{512}{8} \times \frac{512}{8} = 64 \times 64 \text{ pixels}$$

the resultant image after level 2 decomposition of 2D – DWT is:

$$\frac{N_1}{4} \times \frac{N_2}{4} = \frac{512}{4} \times \frac{512}{4} = 128 \times 128 \text{ pixels}$$

the resultant image after level 1 decomposition of 2D – DWT is:

$$\frac{N_1}{2} \times \frac{N_2}{2} = \frac{512}{2} \times \frac{512}{2} = 256 \times 256 \text{ pixels}$$

Given that the filters have 4 coefficients; $K = 4$ and $Sample, N^2 = 64 \text{ bits}^2$

The total number of multiplications and additions per sample is given as:

$$Total \text{ number of operations, } T = KN^2 + \frac{KN^2}{4} + \frac{KN^2}{16}$$

$$T = KN^2 \left(1 + \frac{1}{4} + \frac{1}{16} \right) = \frac{21}{16} KN^2$$

$$T = \frac{21}{16} \times 4 \times 64 = 336 \text{ operations}$$

This implies that per sample of the image, a total number of 336 multiplications and additions are need to compute the 2D – DWT decomposition up to the level 3.

In wavelet-based image approximation, the image is quantized to reduce the precision of the floating-point values of the wavelet transform, and these quantized transform values, wavelet will produce approximately to the image when an inverse transform is

applied, which results in lossy compression. The purpose of the wavelet transform is that it produces a large number of values with zero magnitudes. This transform can set a threshold, and all values with magnitudes more minor than the limit will be set to zero, and a large area of grey background indicates zero in the thresholded transform. Two widely used measures for quantifying the error between images are MSE and PSNR('Bogess_Narcowich.Pdf', no date). The MSE between two images a and b is defined by

$$MSE = 1/N \sum (a [j, k] - b [j, k])^2$$

MSE (Mean square error)

Using MATLAB source code carried, we used Barbara image to approximation to find mean squared error is **378.6702**, which is used in the practical as well to find the Mean square error part with total coefficients.

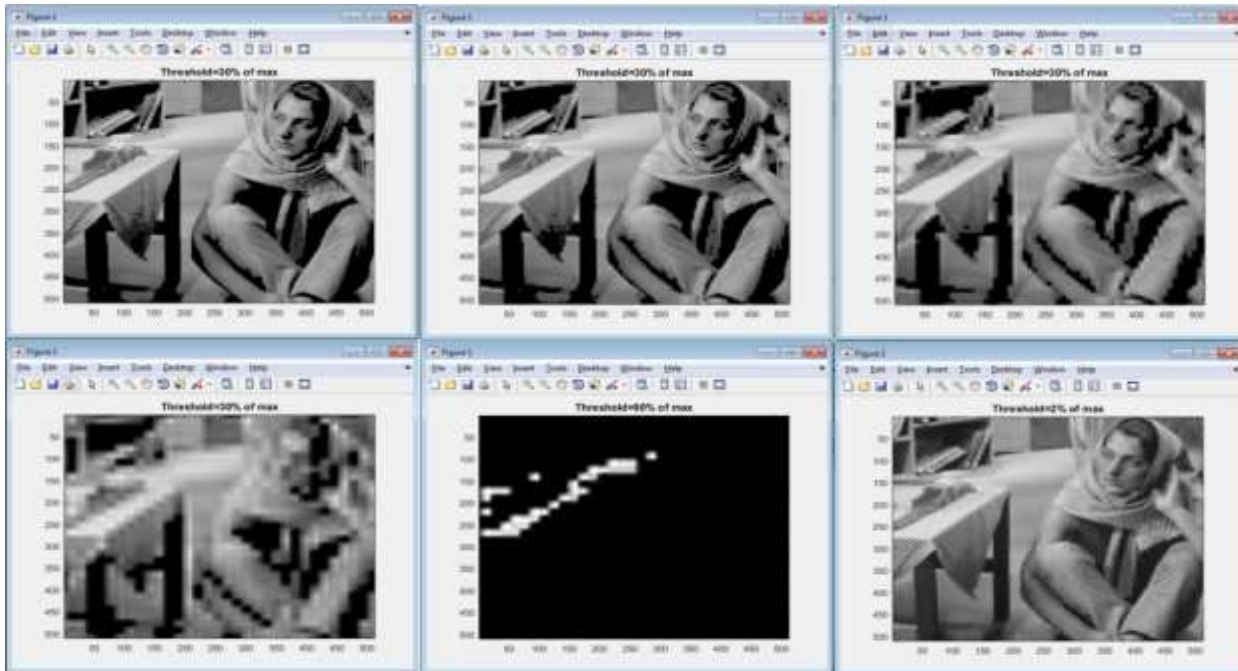

Figure 6: Compressed Image

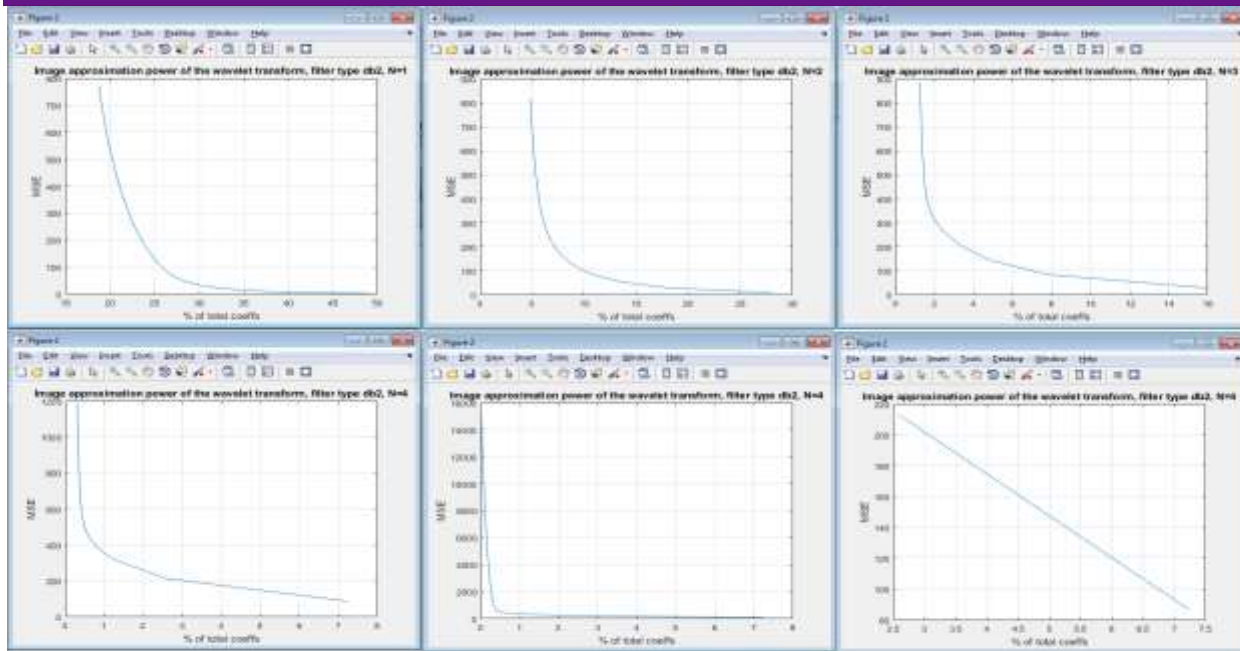

Figure 7: MSE and Total percentage of Coefficient

RESULTS

From left to right in the above schematic-E, the operations during Forward wavelet transform, Thresholding, and Inverse wavelet transform. The down-sampler chooses samples at two intervals and discards the rest in multi-rate signal processing, filtering, and down-sampling. To retain the number of samples during image processing, downsampling is performed at each decomposition level. Because aliasing (distortion) is introduced by downsampling by two, the input signal is sent through a bank of filters (high pass and low pass) to prevent it. The multiplier runs at 1/2 the sampling frequency of the input signal in the first step after downsampling, as indicated. The output is formed by summing the extended sub-band pictures. The length and implementation of the filter distinguish this as a direct form convolution. The wavelet coefficient threshold is chosen according to the original image's pixel intensity, and the image is recreated using the inverse wavelet transform to extract relevant information while minimising background noise in image processing.

CONCLUSION

Wavelet analysis is an efficient time-frequency analysis method and by applying Wavelet analysis a signal can be analyzed down to its sub-band frequencies. Wavelet algorithms process data at different resolutions or scales. By designing the appropriate analytic and compositing filter banks, we can achieve near-perfect reproduction of the original image. The raw resolution analysis method provides an approximate but complete version of the complete image for applications, plus detailed or distinct images. In engineering and computer science, recursive division leads to efficient algorithms for searching, sorting, complex computation, and eigenvalues. The reconstructed image will not match the original image and is not a perfect image. It has error measured by MSE and PSNR to measure the quality of the reconstructed image. Convolution is a mathematical operation that produces a function that represents how the shape of one is changed by the other. The larger coefficients are kept the same, while the smaller ones are set to zero, this is how approximations are made in signal processing.

REFERENCES

- [1] R. Sudhakar, Ms R Karthiga, S. Jayaraman, " Image Compression using Coding of Wavelet Coefficients– A Survey", ICGST-GVIP Journa, vol. 5, no. 6, p. 25-38, 2005. (9)
- [2] T. Singh, S. Chopra, H. Kaur, & A. Kaur. "Image compression using wavelet and wavelet packet transformation. *IJCST*, 1(1), 2010. (9b)
- [3] W. Zhao, M. Zhao and J. Pan, "The Image Compression Technology Based on Wavelet Transform", *Advanced Materials Research*, vol. 1078, pp. 370-374, 2014. Available: 10.4028/www.scientific.net/amr.1078.370. (2)

- [4] J. Nayak, P. B. Subbanna, U, R. Acharya, & M, K. Sathish. Efficient storage and transmission of digital fundus images with patient information using reversible watermarking technique and error control codes. *Journal of medical systems*, 33(3), 163-171, 2009. (2b)
- [5] "The Wavelet Transform", *Medium*, 2022. [Online]. Available: <https://towardsdatascience.com/the-wavelet-transform-e9cfa85d7b34>. [Accessed: 15- Apr- 2022]. (8)
- [6] O.J. Morris, M. D. J. Lee, & A. G. Constantinides, "Graph theory for image analysis: an approach based on the shortest spanning tree". In *IEE Proceedings F (Communications, Radar and Signal Processing)* (Vol. 133, No. 2, pp. 146-152). April, 1986. IET Digital Library. (8b)
- [7] T. Aina , *et.al* ,"Wavelet Transforms and Image Approximation based Image Compression System" *International Journal Of Scientific and Technology Research*, vol. 10, no. 10, pp. 104-107, 2021. (3)
- [8] W. A. Mustafa, H. Yazid, W. Khairunizam, M. A. Jamlos, I. Zunaidi, Z. M. Razlan, & A. B. Shahrman." Image enhancement based on discrete cosine transforms (DCT) and discrete wavelet transform (DWT)": A review. In *IOP Conference Series: Materials Science and Engineering* (Vol. 557, No. 1, p. 012027). 2019, June. IOP Publishing. (3b)
- [9] D. Marpe, G. Blattermann, J. Rieke and Maass, "A two-layered wavelet-based algorithm for efficient lossless and lossy image compression", *IEEE Transactions on Circuits and Systems for Video Technology*, vol. 10, no. 7, pp. 1094-1102, 2000. Available: 10.1109/76.875514. (4)
- [10] T. Lu, Q. Liu, X. He, H. Luo, E. Suchyta, J. Choi, ... & Z. Qiao, (2018, May). Understanding and modeling lossy compression schemes on HPC scientific data. In *2018 IEEE International Parallel and Distributed Processing Symposium (IPDPS)* (pp. 348-357) May, 2018. IEEE. (4b)
- [11] A. Graps, "An introduction to wavelets", *IEEE Computational Science and Engineering*, vol. 2, no. 2, pp. 50-61, 1995. Available: 10.1109/99.388960. (7)
- [12] J. C. Letelier, & P. P. Weber, "Spike sorting based on discrete wavelet transform coefficients". *Journal of neuroscience methods*, 101(2), 93-106. 2000. (7b)
- [13] S. Sharma and U. Bhat, "Image Compression using an efficient hybrid algorithm", *Journal on Today's Ideas-Tomorrow's Technologies*, vol. 1, no. 1, pp. 45-50, 2013. Available: 10.15415/jotitt.2013.11004. (13)
- [14] M. Rhif, A. Ben Abbes, I. Farah, B. Martínez and Y. Sang, "Wavelet Transform Application for/in Non-Stationary Time-Series Analysis: A Review", *Applied Sciences*, vol. 9, no. 7, p. 1345, 2019. Available: 10.3390/app9071345. (6)
- [15] T. K, Al-Shayea, C. X Mavromoustakis, J. M. Batalla, & G. Mastorakis. "A hybridized methodology of different wavelet transformations targeting medical images in IoT infrastructure *Measurement*". 148, 106813, 2019. (6b)
- [16] "The Wavelet Transform", *Medium*, 2022. [Online]. Available: <https://towardsdatascience.com/the-wavelet-transform-e9cfa85d7b34>. [Accessed: 15- Apr- 2022]. [8]
- [17] T. Aina, O.O. Akinte, B. Iyaomolere, A.E. Tosin, I.I. Abode, & A.J. Awelewa. Implementation of an intelligent motion detector. *International Research Journal of Engineering and Technology*, 9(1), 1148-1165, 2022.
- [18] *Dspace.mit.edu*, 2022. [Online]. Available: <https://dspace.mit.edu/bitstream/handle/1721.1/80511/4/3313432-MIT.pdf;sequence=2>. [Accessed: 15- Apr- 2022]