

# Design and Implementation of the Kerwin – Huelsman - Newcomb (KHN) Biquad Filter for Very Low Frequency (VLF) Applications.

Atsuwe, B.A

Department of Science Education, Joseph Sarwuan Tarka,  
University Makurdi, Benue state, Nigeria.  
E-mail: [atsuwe.bernard@uam.edu.ng](mailto:atsuwe.bernard@uam.edu.ng)

**Abstract:** The Kerwin- Huelsman- Newcomb (KHN) second-order Band pass filter was designed and simulated for implementation in the very low frequency (VLF) bands. Six (6) resistors, two (2) capacitors, three (3) op-amps of  $\mu A741$  type, connectors and NI multisim version 14.2 software was used for the design and simulation. Results show that the centre frequency ( $\omega_o$ ) of 16.595 kHz which was slightly sifted was recorded. The mid-band gain recorded was 21.79db; the bandwidth recorded was 1.15 kHz and a roll-off rate that approached single-pole second order of -27.19db/decade with a little overshoot. It is then concluded that the KHN filter can be used for the implementation at very low frequency (VLF) applications. It can be recommended that further studies be carried out at other frequency bands in order to ascertain the functionality of the KHN filter at those frequency levels.

**Keywords:** Design, Implementation, KHN Filter, VLF, Biquad

## 1. INTRODUCTION

Analog filters play a vital role in modern electronic circuit Applications which were believed to form the basic blocks. Very low frequencies (VLF) occupy a band of frequencies from 3 KHz to 30 KHz and are very important in the applications as diverse as possible. Such applications may include robust low-data rate communications under water underground applications, assured precision Navigation and Timing (APNT), and in urban environments, etc. in the case, sensors are then needed to harvest the signals they need which may include weak ones, this weak ones need to be amplified and sent to the circuit for processing. The signals collected in riddled with all kinds of noise that needs to be separated from the band of frequencies of interest, thereby necessitating the use of filters. It is believed that, as the frequency of operation of a system is reduced, the design becomes easier and fewer problems are encountered. (papananos, Georgantas, and Tsvividis, 1997). This is not true, especially for frequencies below 1 kHz, which is enumerated in the literature (Shah, 1993; Deguelle, 1988; Mueller, et al. 1989; Steyaert, et al. 1991). The literature, though basically deals with the implementation of very large time constant in CMOS technologies. As far as these authors know, the only high filtering systems that have appeared operate at frequencies above 1 kHz (e.g. Kaiser, A. 1989). Low frequency filters design has issues of large time constants, values of resistors and capacitors that are limited by the silicon area available, parasitic elements which is directly connected to the large size of the devices and filter noise of the active elements which give rise to noise and in turn reduces the dynamic range of system. Fortunately, solutions have been suggested for the above problems like investigative techniques for large time constants which are on-going, special compensating techniques utilized for the elimination of deteriorating performance as a result of parasitic effect etc. hence the choice of Kerwin – Huelsman Newcomb (KHN) filter which has potential to overcome some of the challenges encountered in the design of Ultra-Low Frequency (ULF or ELF), very – Low Frequency (VLF), low frequency (LF) and Medium Frequency (MF) range of filters. The KHN (Kerwin – Huesman – Newcomb) filter is one of well-known biquads and offers several advantages such as low components spread, low passive and active sensitivity performance, good stability behaviour (Kerwin, Huelsman, & Newcomb, 1967 in Jaroslav, et al. ND). The KHN provides simultaneous filtering of Low-pass (LP), High-pass (HP), and Bandpass (BP) functions. In the area of microelectronics, the progress made improves the properties of active elements in current feedback amplifiers (CFA) (Maundy, et al. 2006), Operational Trans-conductance Amplifiers (OTA) (Yang, et al. 2005), current conveyors (CC) (Bensalem, et al. 2005), or voltage conveyor (Filanovshy, 2001). Most of the active elements are usually implored in the implementation of filter frequencies that are in line with the KHN filter (Distal, 1998; Shah, & Bhaskar, 2002; Altuntas, & Toker, 2002; Ibrahim, et al. 2005; koton, et al. 2009). The active components help to cut down the number of drifting passive parts in the structure, which is used for integration and implementation (Bhusan, & Newcomb, 1967). This paper builds on the advantages of the KHN filter enumerated above for implementation in the very low frequency (VLF) region.

## 2. MATERIALS AND METHODS

The Kerwin – Huelsman – Newcomb (KHN) filter is used to implement the second-order band pass filter that is made up of one summer amplifier and two integrators (one a lossy integrator) with  $R_4$  and  $R_5$  as the feedback paths. This filter offers three output voltage terminals at  $V_2(S)$ , and  $V_3(S)$  and  $V_4(S)$  for high-pass, Band pass and low – pass filters respectively. Furthermore, the transfer functions have the same poles. This Architecture was chosen because of its advantages over other structures like the Sallen-key filter which is a single amplifier coupled in a passive RC network that generates a second – order transfer function. Even though the structure of a sallen-key filter is comparatively simple to design, it is however prone to great sensitivity to the constituent

components' values. The KHN filter which is a type of state – variable biquad can be used to achieve high quality value of a designed circuit, this implies selectivity. Again this type of state variable biquad can give flexibility in the circuit, good performance, and low sensitivity. This circuit is implemented based on the state – variable approach that is usually employed in the development of its realisation using the state –variable method of solving differential equations.

The materials used in the design of the KHN filter are six (6) Resistors, two (2) capacitors, and three (3) op-amps of  $\mu A741$  type, three connectors, and one software NI Multisim version 14.2 for simulation. The op-amp contains one summer, one integrator and one lossy- integrator. Figure 1 below shows the Kerwin-Huelsman-Newcomb second order bandpass filter that is designed and simulated.

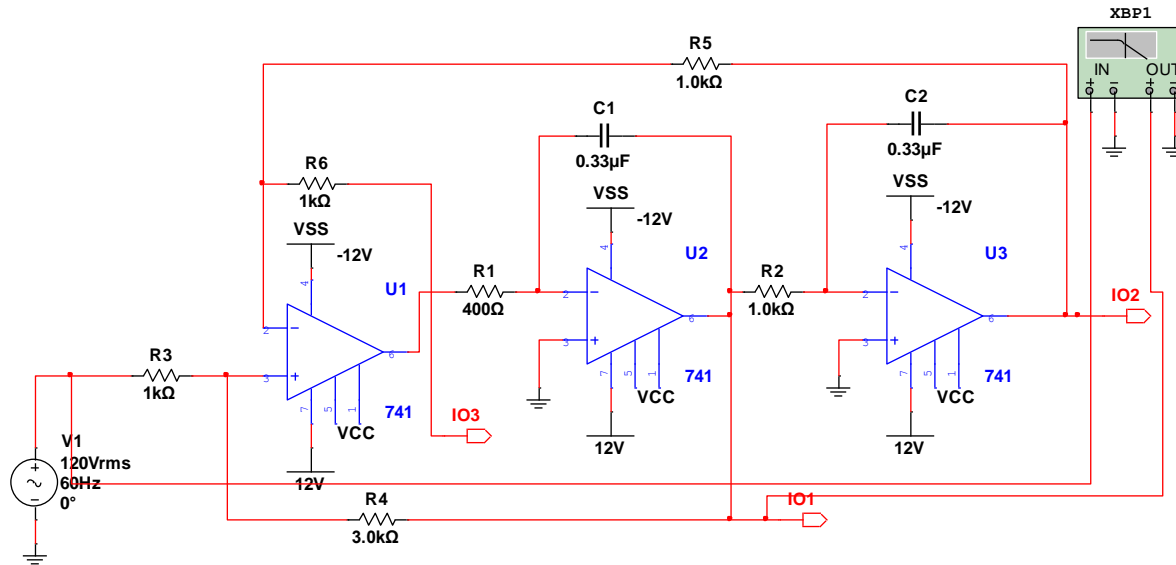

Figure 1. The designed KHN second – order Bandpass Filter:

**2.1 DESIGN SPECIFICATION**

The Bandpass transfer function is given as:

$$\frac{V_3(S)}{V_1(S)} = \frac{-H_{BP} \left(\frac{W_0}{Q}\right) S}{S^2 + \left(\frac{W_0}{Q}\right) S + W_0^2} \text{-----(1)}$$

Where the voltage gains  $H_{BP}$  at the centre frequency ( $W_0$ ) is given as:

$$H_{BP} = \frac{R_4}{R_3} \text{----- (2)}$$

The centre frequency ( $W_0$ ) was chosen from the band of very low frequency of (3kHz – 30kHz) which gives 16.5kHz, the quality factor (Q) of 10 was also chosen and a gain of 3. The capacitor value C was chosen such that  $C_1 = C_2 = C = 48.5nF$ . again, the resistor values were chosen such that  $R_2, R_3, R_5$  and  $R_6$  have the same values for simplicity, thus,  $R_2 = R_3 = R_5 = R_6 = R = 1k\Omega$ . Other designed values were calculated from the equations stated below,

Positive constant number  $\alpha$ :  $R_1 = \alpha^2 R_2 = \alpha^2 R \text{----- (3)}$

$$R = \frac{1}{W_0 \alpha C} \text{-----(4);}$$

$$\alpha = \frac{2Q}{H_{BP} + 1} \text{-----(5);}$$

$$W_0 = \frac{1}{\alpha RC} \text{-----(6)}$$

$$Q = \frac{\alpha}{2} \left(1 + \frac{R_4}{R_3}\right) \text{----- (7)}$$

$$H_{Bp} = 2 \frac{Q}{\alpha} - 1 \text{ --- (8)}$$

$$R_4 = \left( 2 \frac{Q}{\alpha} - 1 \right) R \text{ --- (9)}$$

Using equation 2-9, above, the following values were obtained

$\alpha = 5.0$  using equation (4),  $R_1 = 25k\Omega$  using equation (3)  $R_4 = 3.0k\Omega$  using equation (9) as presented in Table 1.

Table 1: Values of Quality factor, Q and Respective Calculated Resistors and Capacitor values

S/N	Q	$R_1(K\Omega)$	$R_2(K\Omega)$	$R_3(K\Omega)$	$R_4(K\Omega)$	$R_5(K\Omega)$	$R_6(K\Omega)$	C (nF)
1	10	25.0	1.0	1.0	3.0	1.0	1.0	48.50

### 3. RESULT AND DISCUSSION

The result of the magnitude response curve from the KHN second order filter obtained from the simulation is presented in figure 2 and measured filter parameters is presented in Table 2.

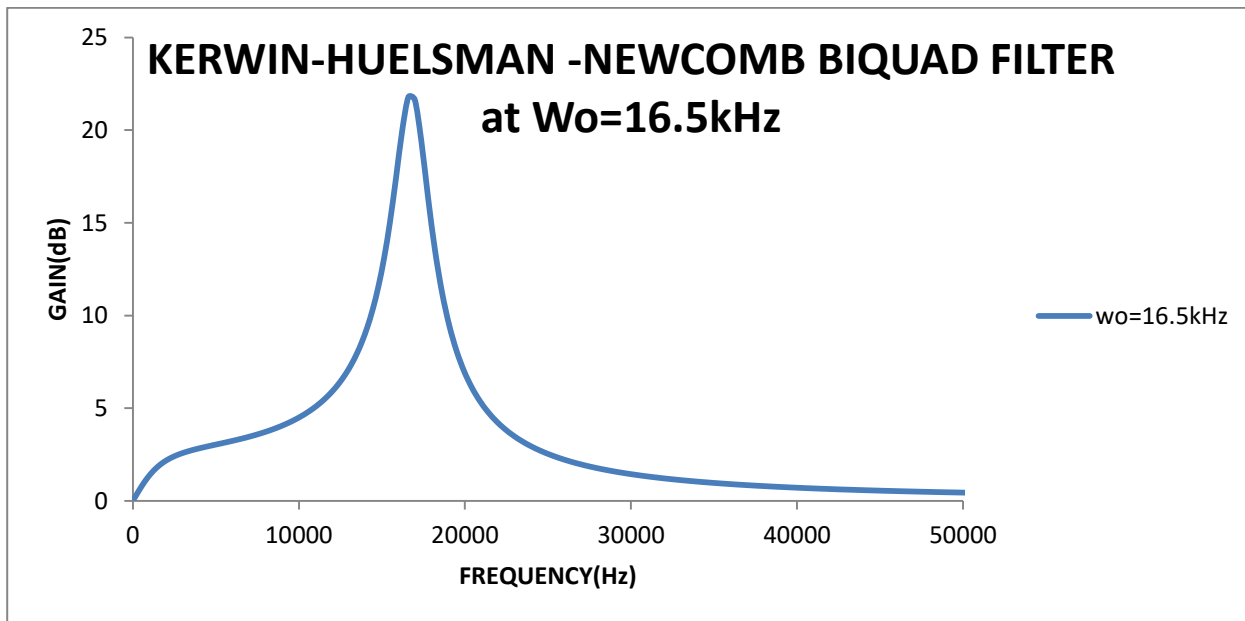

Figure 2. Magnitude response curve for Kerwin-Huelsman-Newcomb Biquad second-order filter

Table 2: Measured Filter Parameters of cut-off frequency  $W_o$ , Bandwidth (BW), and roll-off Rate

S/N	Q	Centre freq. (kHz)	Midband gain (dB)	-3dB gain	FH (kHz)	FL (kHz)	Bandwidth BW (kHz)	Roll-off rate dB/decade
1	10	16.595	21.798	18.79	17.37	16.22	1.15	-27.19

Figure 2 and Table 2 presents the magnitude plot and results from the simulated KHN second-order Bandpass filter at very low frequency of 16.5 kHz. The pass band is 3 kHz to 30 kHz and Quality factor (Q) of 10.

The result in Table 2 shows a centre frequency ( $W_o$ ) = 16.595kHz which is a bit shifted to approximately 16.60kHz and recorded a midband gain of 21.79dB, while an observed Bandwidth value of 1.15kHz was recorded. The roll-off rate for the filter approached -27.19dB/decade which shows a second order single pole filter.

## Conclusion

The KHN second-order bandpass filter was designed and simulated and the measured values from the simulated result satisfy the filter specification in terms of centre frequency, Midband gain, Bandwidth and a roll-off rate that approached a single-pole second order Band pass filter. Therefore, it can be concluded that the designed filter can be implemented in the very low frequency (VLF) bands in radio receivers.

## REFERENCES

1. Papananos, Y., Georgantas, T., and Tsvividis, Y. (1997). Design Consideration and Implementation of very low Frequency Continuous-time CMOS monolithic Filters. IEE Proceedings-circuit Devices and systems, vol. 144. No. 2. 68-74.
2. Shah, P., 'Design of analogue integrated Circuits for very low frequency signal processing'. Ph.D dissertation Univ. Denmark, Nov. 1993.
3. Deguelle, W, "Limitations on the integration of analog filters for frequencies below 10Hz", IEEE – ESSCIR, 1998, PP.131 – 134.
4. Mueller, P. et al. "Design and Fabrication of VLSI Components for a general purpose analog neural computer". Analog VLSI Implementation of neural systems (Kluwer Academic Publishers, 1989) PP. 135 – 169.
5. Steyaert, M., Kinget, P., Sansen, W., and Van Der Spiegel, J.(1991) 'Full integration of extremely large time constants in CMOS', Electron, 27, (10), PP. 790 – 791.
6. Kaiser, A. (1989). 'A micropower CMOS Continuous time low pass filter; IEEE). Solid state circuits, SC-24, (3), PP. 736-743.
7. Kerwin, W., Huelsman, L., and Newcomb, R. (1967). 'State variable synthesis for insensitive integrated circuits, vol. SC-2, No. 3, PP. 87 – 92.
8. Maundy, B.J., Sarkar, A.R., and Gift, S.J. (2006). "A new Design Topology for low voltage CMOS current feedback Amplifiers", IEEE Trans. Circuits and systems II, vol. 53. No1, PP 34 -38.
9. Yang, S-H., Kim, K-H., Kim, Y-H., You, Y., and Cho, K-R. (2005). "A Novel CMOS operational trans conductance Amplifier Based on a Mobility Compensation Technique" IEEE Circuits and systems II, Vol.52. No 1, PP. 37-42.
10. S.Bensalem, M Faxhfakh, M.Loulou, N.Masmoudi, "An improved High performance CMOS second Generation current conveyor" IEEE Circuit and systems, Proc. ISSCS 2005, vol.2 PP693 – 696.
11. Filanovsky, I.M. (2001). "CMOS Voltage Conveyors, Proc of the 44<sup>th</sup> IEEE Midwest symposium on circuits and systems, vol.1, PP. 318 – 321.
12. Dostal, T. (1998) "High Frequency state variable biquadratic active-filters", Radioengineering, vol. 7, No. 1, PP. 1 – 6
13. Shah, S. and Bhaskar, D.R. "Design of KHN biquad using operational trans-conductance amplifier", IEEE circuits and systems, Proc. MWSCAS 2002, PP. 1- 48 - 51.
14. Altuntas, E., and Toker, A. (2002). "Realization of voltage and current mode KHN biquads using CCCIS", int. J. Electronics commun. (AEU), vol. 56, PP 45 – 49.
15. Ibrahim, M.A., Minaesi, S., and Kuntaman, H. (2005). "A 22.5MHz current mode KHN-biquad using differential voltage current conveyor and grounded passive elements", int. J. Electronics Commun. (AEU), vol. 59, PP 313 – 318.
16. J.Koton, K. Vrba, N. Herencsar, "Variable Q and  $W_o$  multifunction filter using universal voltage conveyors", in 2009 RISP int; Workshop on non-linear circuits and signals proc. March 2009 Hawaii.
17. Bhusan, M., and Newcomb, R.W. "Grounding of capacitors in integrated circuits", Electronics Letters, 1967, vol. 3, PP 148 – 149.
18. Jaroslav,K., Norbert, H., Kamil, V., and Oguzhan, C. "Kerwin – Huelsman – Newcomb Filters using DVCCs. C zech science Foundation project GACR 102/09/1681, and Ministry of Education of the Czech Republic Project No. MSM0021630513.